



PROHLÁŠENÍ O VLASTNOSTECH



č. 0004 – CS

1. Jedinečný identifikační kód typu výrobku: **fischer termoz CS 8**

2. Zamýšlené/zamýšlená použití:

Výrobek	Zamýšlené/zamýšlená použití
Plastové hmoždinky pro použití do betonu a zdiva.	Plastová hmoždinka se šroubem pro upevnění vnějších tepelně izolačních kompozitních systémů s omítkou do betonu, zdiva, lehčeného betonu a pórobetonu., viz. doplněk, obzvláště Přílohy B 1 - B 3

3. Výrobce: **fischerwerke GmbH & Co. KG, Klaus-Fischer-Straße 1, 72178 Waldachtal, Německo**

4. Zplnomocněný zástupce: --

5. Systém/systémy POSV: **2+**

6a. Harmonizovaná norma: ---

Oznámený subjekt/oznámené subjekty: ---

6b. Evropský dokument pro posuzování: **ETAG 014; 2011-02**

Evropské technické posouzení: **ETA-14/0372; 2015-02-27**

Subjekt pro technické posuzování: **ETA-Danmark A/S**

Oznámený subjekt/oznámené subjekty: **1343 – MPA Darmstadt**

7. Deklarovaná vlastnost/Deklarované vlastnosti:

**Bezpečnost při použití (BWR 4)**

<b>Základní vlastnosti</b>	Viz. dodatek, obzvláště Příloha C 1 - C 4
----------------------------	---

8. Příslušná technická dokumentace a/nebo specifická technická dokumentace: ---

Vlastnosti výše uvedeného výrobku jsou ve shodě se souborem deklarovaných vlastností. Toto prohlášení o vlastnostech se v souladu s nařízením (EU) č. 305/2011 vydává na výhradní odpovědnost výrobce uvedeného výše.

Podepsáno za výrobce a jeho jménem:

Andreas Bucher, Dipl.-Ing.

Wolfgang Hengesbach, Dipl.-Ing., Dipl.-Wirtsch.-Ing.

Tumlingen, 2015-03-09

- Toto PoV bylo připraveno v různých jazykových mutacích.. V případě rozporu vždy rozhoduje interpretace verze v anglickém jazyce.

- Příloha obsahuje nepovinné a doplňkové informace v anglickém jazyce na rámec zákonných požadavků.

## **1 Technical description of product and intended use**

### **Technical description of the product**

The screwed-in anchor fischer termoz CS 8 for fixing of external thermal insulation composite systems (ETICS) consists of an anchor sleeve made of polypropylene with a diameter of 8 mm and an insulation plate made of glass-fiber reinforced polyamide with a diameter of 60 mm. The color of the anchor sleeve is grey. The special compound screw is made of galvanized steel and glass-fiber reinforced polyamide. The anchor is expanded by screwing the screw into the sleeve. It is possible to install the anchor flush or deep-mounted to the surface of the insulation.

The product description is given in Annex A.

## **2 Specification of the intended use in accordance with the applicable EAD**

The performances given in Section 3 are only valid if the anchor is used in compliance with the specifications and conditions given in Annex B1 to B3

The provisions made in this European Technical Assessment are based on an assumed intended working life of the anchor of 25 years.

The indications given on the working life cannot be interpreted as a guarantee given by the producer or Assessment Body, but are to be regarded only as a means for choosing the right products in relation to the expected economically reasonable working life of the works.

### **3 Performance of the product and references to the methods used for its assessment**

#### **3.1 Characteristics of product**

##### **Mechanical resistance and stability (BWR 1):**

The essential characteristics regarding mechanical resistance and stability are included under the Basic Works Requirement Safety in use.

##### **Safety in case of fire (BWR 2):**

No Performance determined

##### **Hygiene, health and the environment (BWR3):**

The product does not contain/release dangerous substances specified in TR 034, dated March 2012.

Regarding the dangerous substances contained in this European Technical Assessment, there may be other requirements applicable to the products falling within its scope (e.g. transposed European legislation and national laws, regulations and administrative provisions). In order to meet the provisions of the Construction Products Regulation, these requirements need also to be complied with, when and where they apply.

##### **Safety in use (BWR4):**

The essential characteristics are detailed in the Annex from C1 to C4.

##### **Sustainable use of natural resources (BWR7)**

No performance determined

Other Basic Requirements are not relevant.

##### **General aspects**

The verification of durability is part of testing of the essential characteristics. Durability is only ensured if the specifications of intended use according to Annex B are taken into account.

#### **3.2 Methods of assessment**

The assessment of fitness of the anchor for the intended use in relation to the requirements for mechanical resistance and stability and safety in use in the sense of the Basic Requirements 4 has been made in accordance with the Guideline for European Technical Assessment of "Plastic anchors for fixing of external thermal insulation composite systems with rendering", ETAG 014, Edition February 2011.

In addition to the specific clauses relating to dangerous substances contained in this European technical Assessment, there may be other requirements

applicable to the products falling within its scope (e.g. transposed European legislation and national laws, regulations and administrative provisions). In order to meet the provisions of the Construction Products Regulation, these requirements need also to be complied with, when and where they apply.

## **4 Assessment and verification of constancy of performance (AVCP)**

### **4.1 AVCP system**

According to the decision 97/463/EC of the European Commission, the system(s) of assessment and verification of constancy of performance (see Annex V to Regulation (EU) No 305/2011) is 2+.

**termoz CS 8 / 110-230**

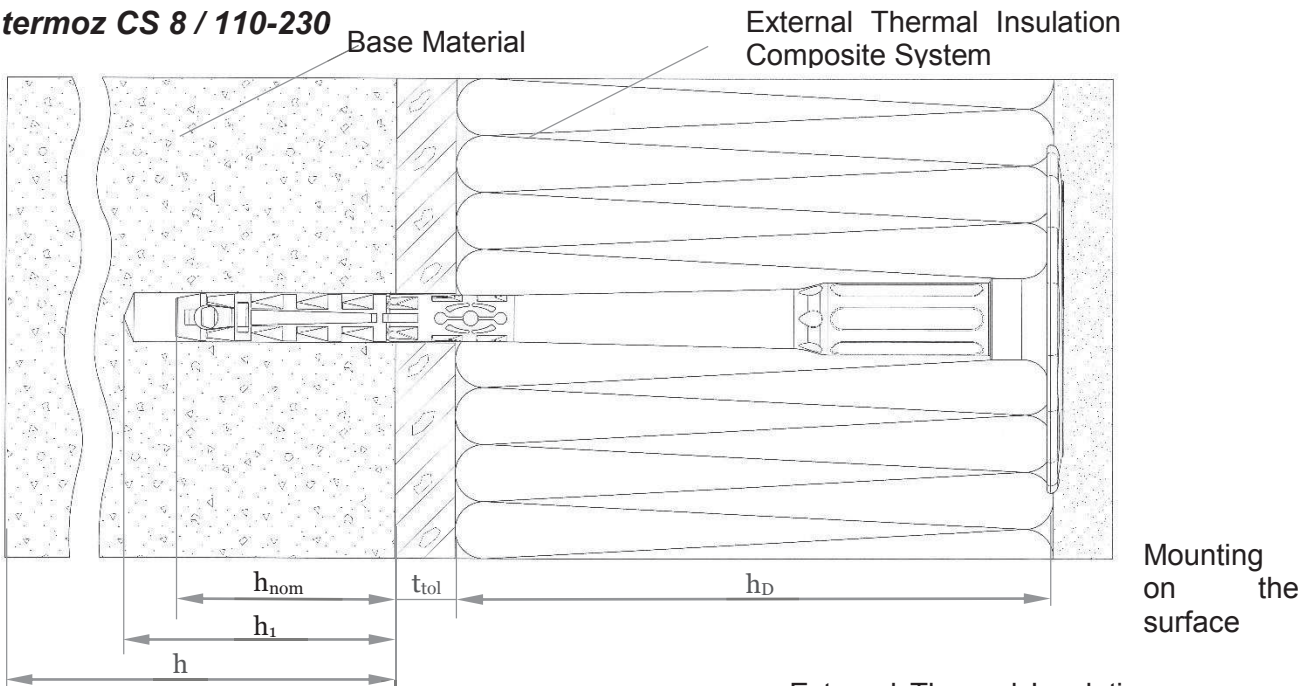

**termoz CS 8 / 250-390**

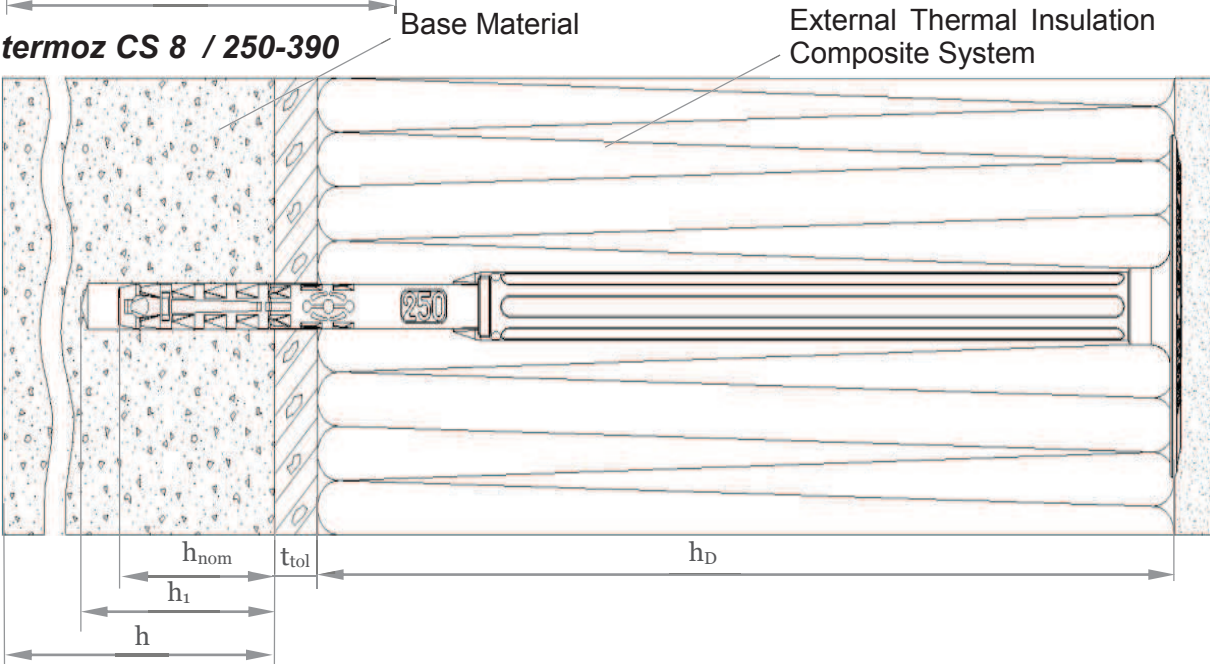

**Legend**

- $h_{nom}$  = Overall plastic anchor embedment depth in the base material
- $h_1$  = Depth of drilled hole to deepest point
- $h$  = Thickness of member (wall)
- $h_D$  = Thickness of insulation material
- $t_{tol}$  = Thickness of equalizing layer or non-load bearing coating

**fischer termoz CS 8**

**Annex A1**

Product description - Installed anchor

**termoz CS 8 / 130-230**

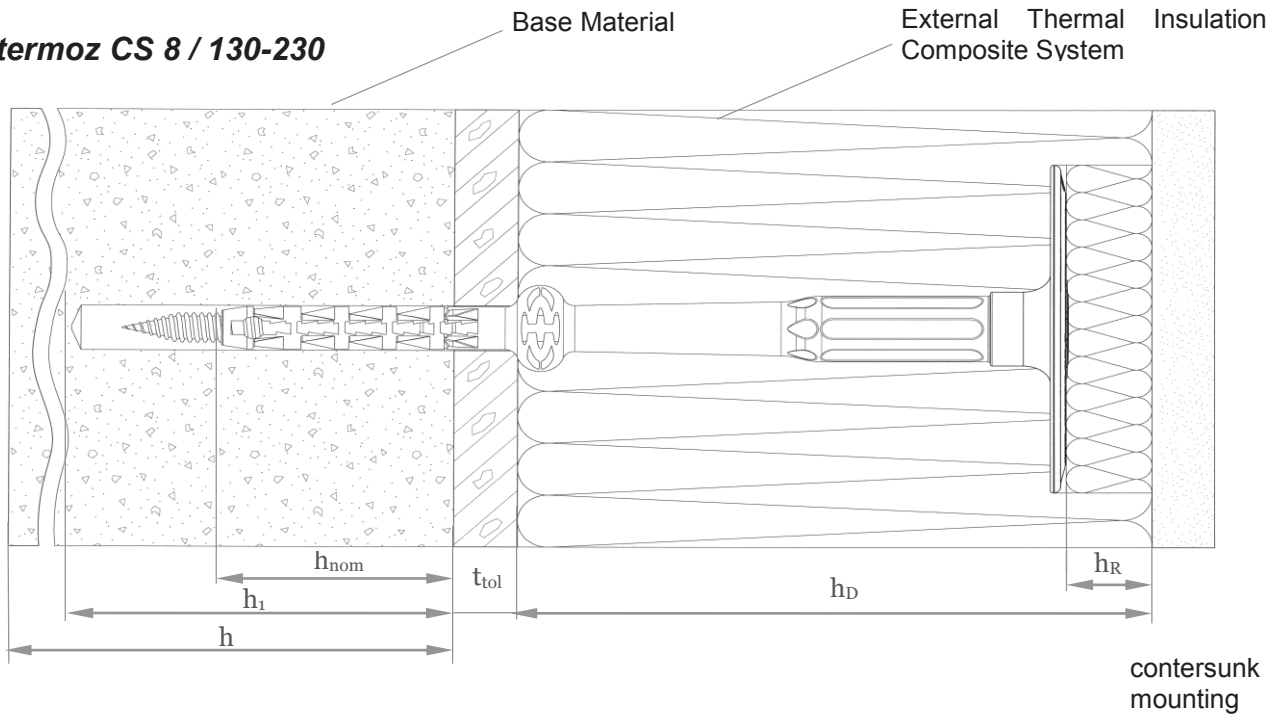

**termoz CS 8 / 250-390**

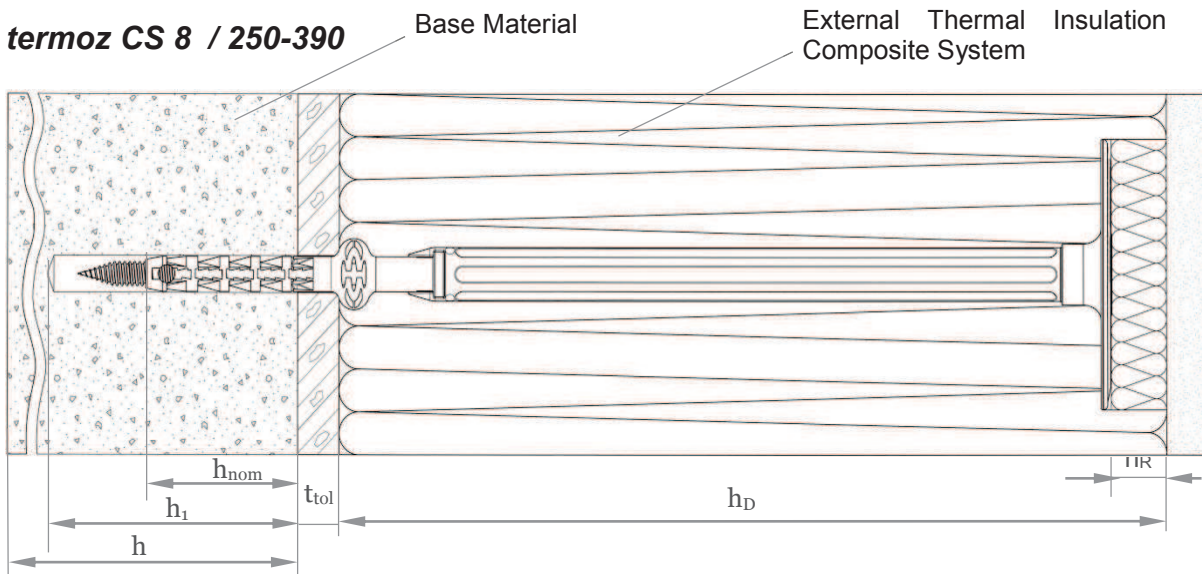

**Legend**

- $h_{nom}$  = Overall plastic anchor embedment depth in the base material
- $h_1$  = Depth of drilled hole to deepest point
- $h$  = Thickness of member (wall)
- $h_D$  = Thickness of insulation material
- $t_{tol}$  = Thickness of equalizing layer or non-load bearing coating
- $h_R$  = Thickness of insulation cap

**fischer termoz CS 8**

**Annex A2**

Product description - Installed anchor



**termoz CS 8 / 130-230 DT 110 V**

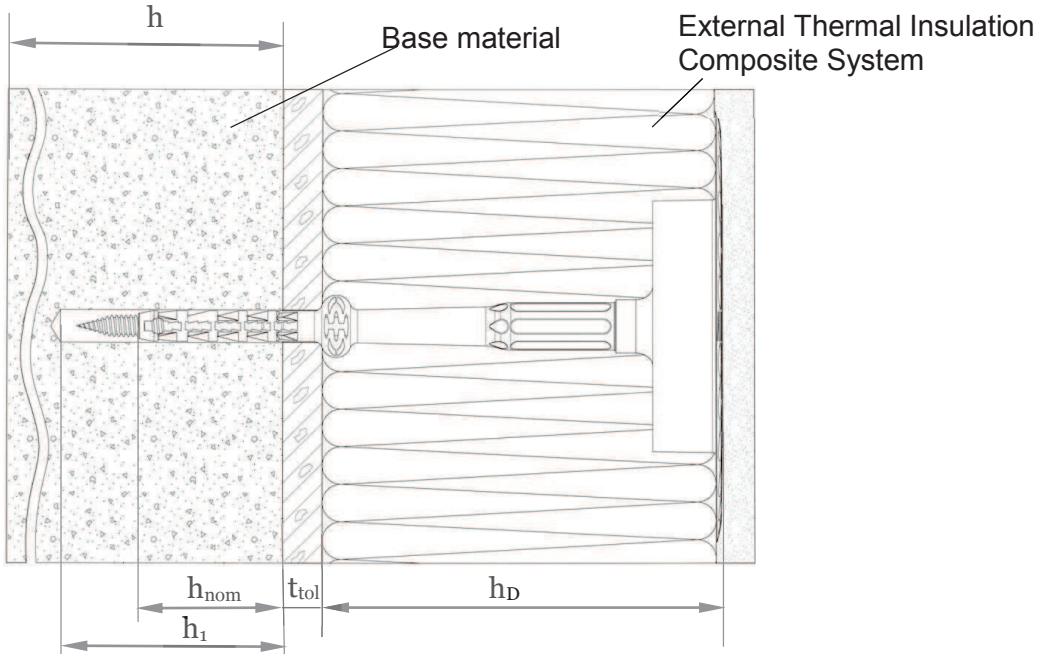

**termoz CS 8 / 250-390 DT 110 V**

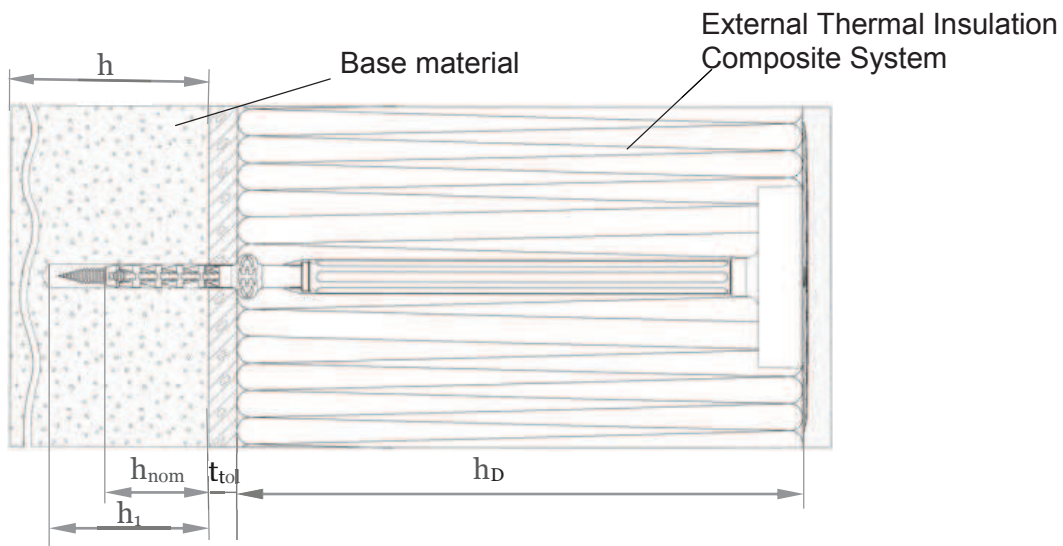

**Legend**

- $h_{nom}$  = Overall plastic anchor embedment depth in the base material
- $h_1$  = Depth of drilled hole to deepest point
- $h$  = Thickness of member (wall)
- $h_D$  = Thickness of insulation material
- $t_{tol}$  = Thickness of equalizing layer or non-load bearing coating

**fischer termoz CS 8**

**Annex A3**

Product description - Installed anchor

**Anchor sleeve / Specific screw for termoz CS 8 110-230**

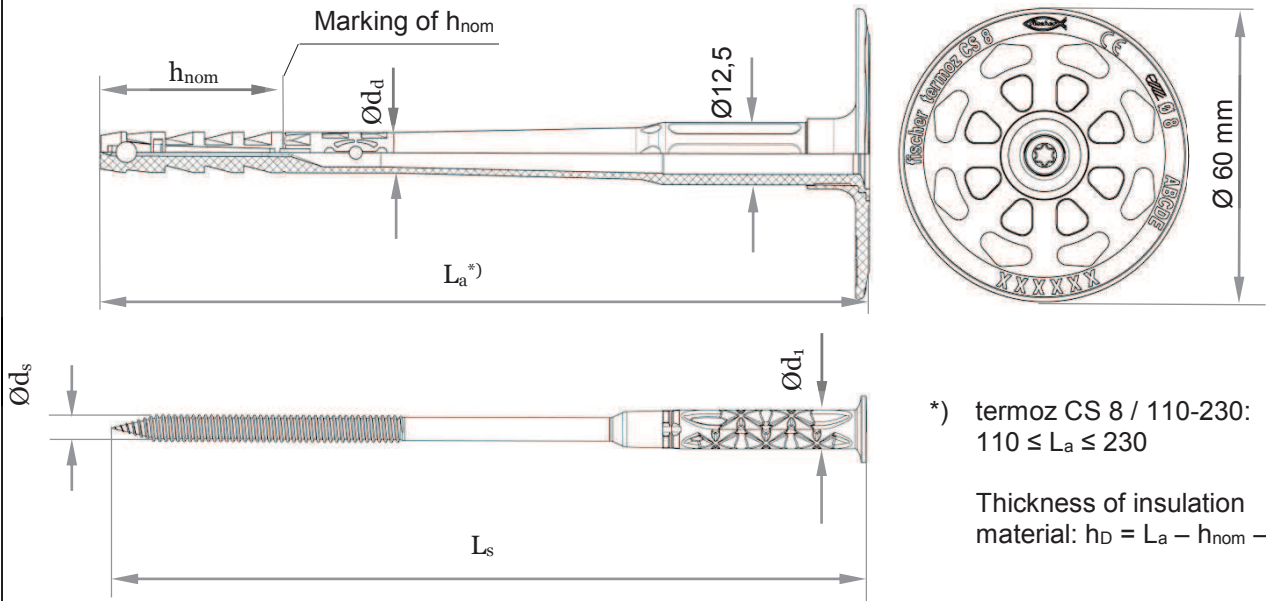

\*) termoz CS 8 / 110-230:  
 $110 \leq L_a \leq 230$

Thickness of insulation  
 material:  $h_D = L_a - h_{nom} - t_{tol}$

**Setting tool with SDS adapter or hexagonal adapter available**

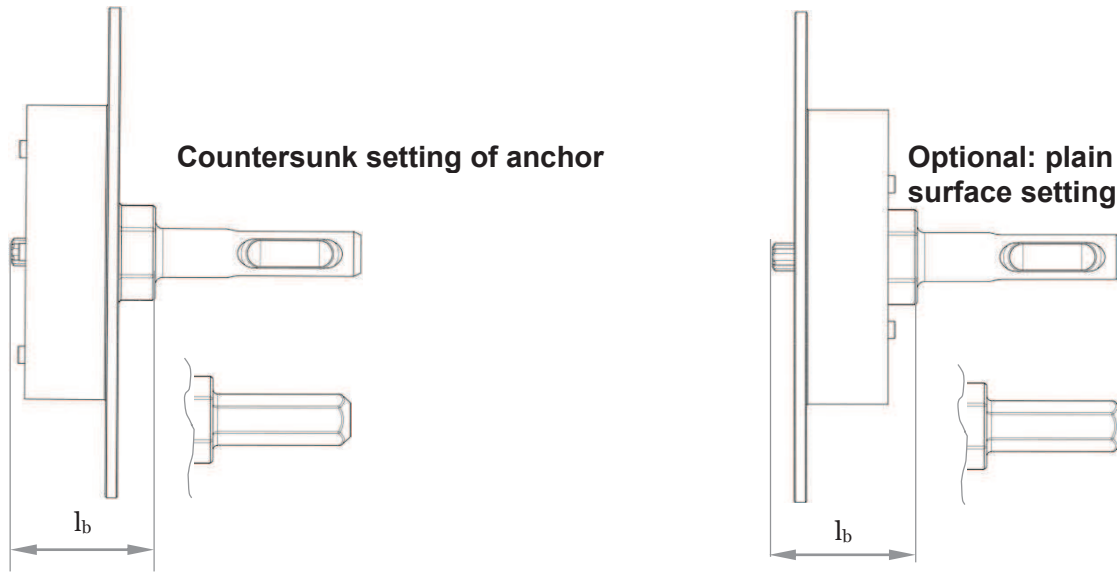

**Polystyrene or mineral wool caps**

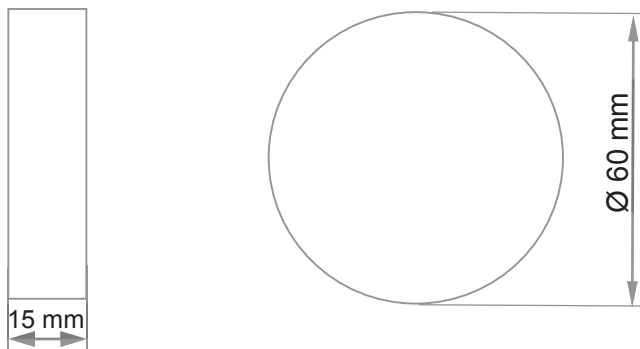

**fischer termoz CS 8**

**Annex A4**

Product description - Dimension



**Shaft / Anchor sleeve / Specific screw for termoz CS 8 250-390**

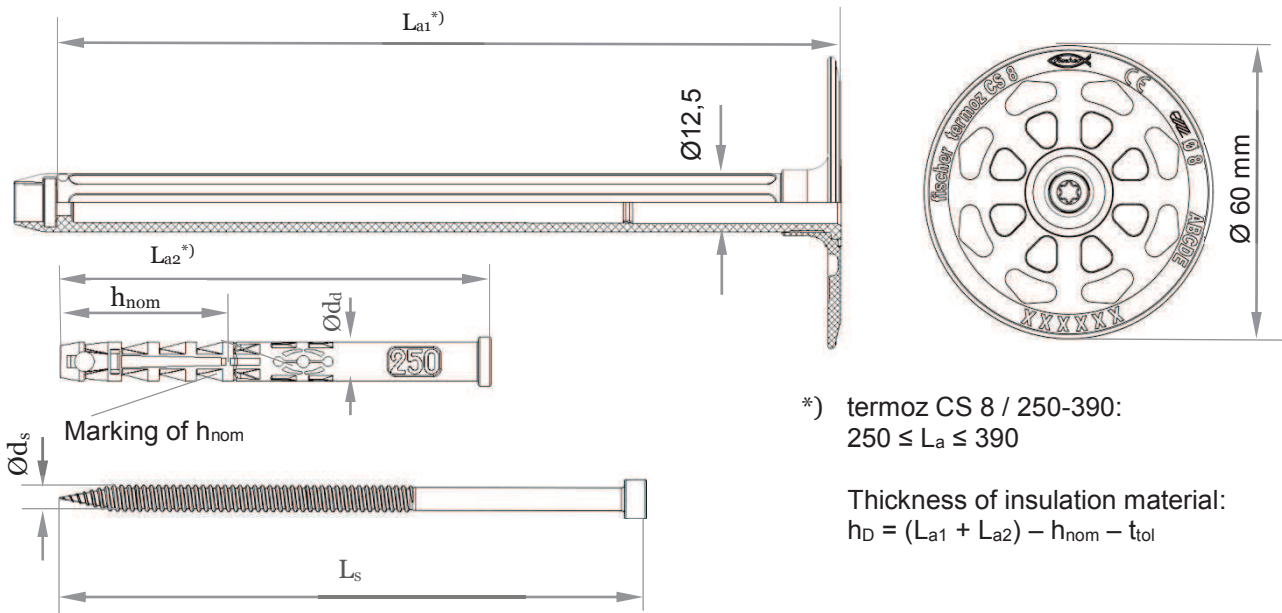

**Setting tool with SDS adapter or hexagonal adapter available**

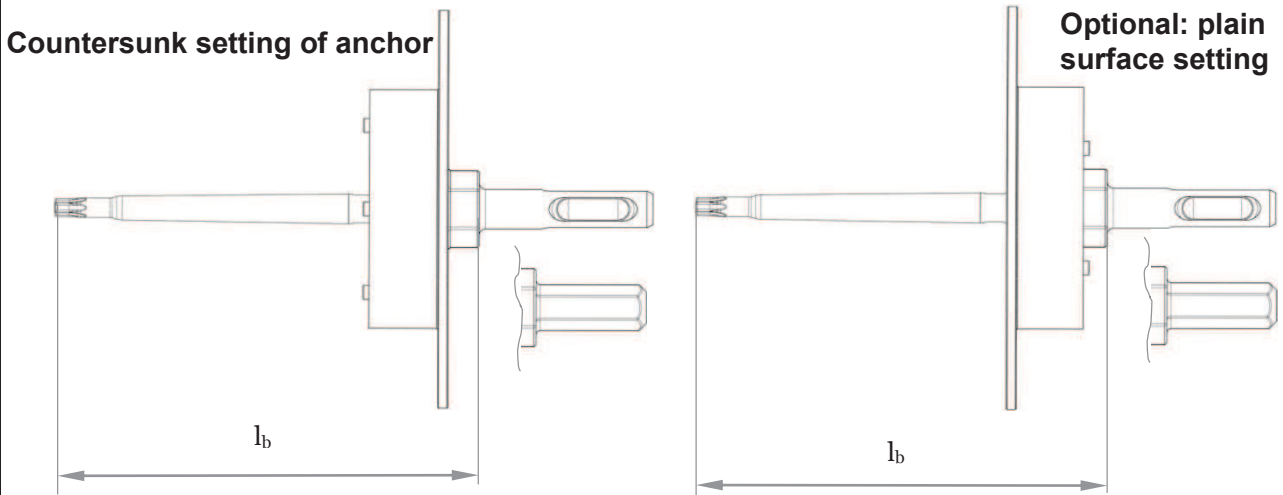

**Polystyrene or mineral wool**

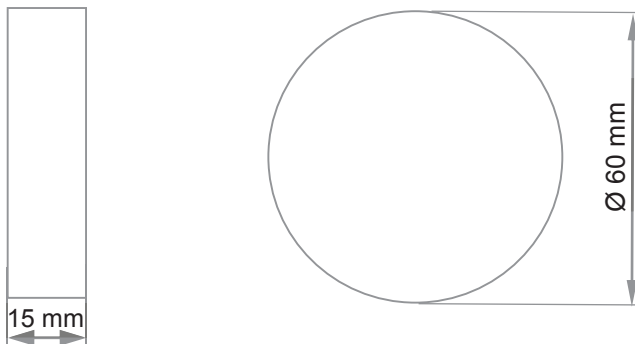

**fischer termoz CS 8**

**Annex A5**

Product description - Dimension

**termoz CS 8 / 130-230 DT 110 V**

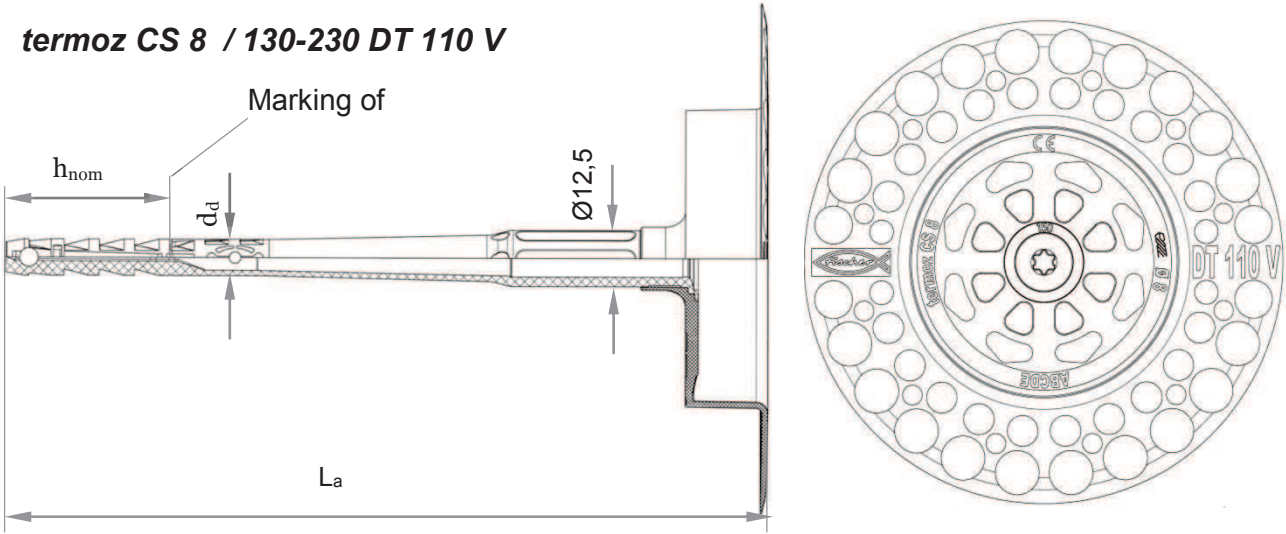

Setting tool with SDS adapter or hexagonal adapter available

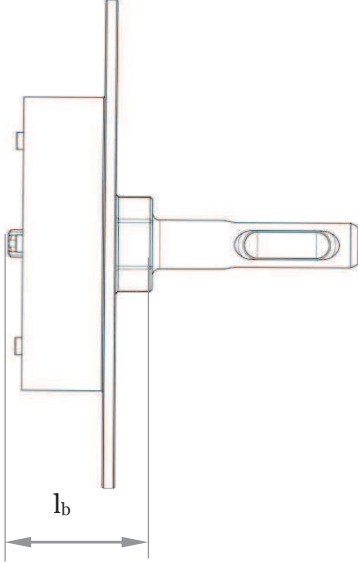

Polystyrene or mineral wool caps

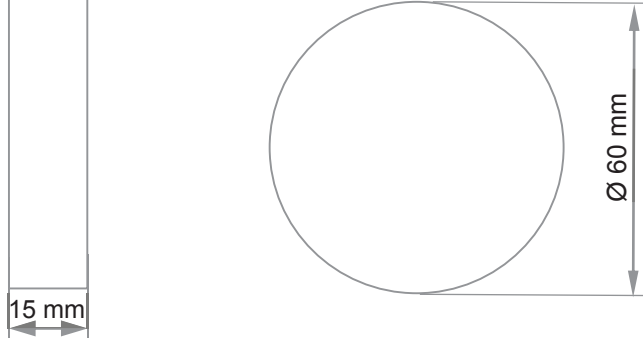

<p>fischer termoz CS 8</p>	<p>Annex A6</p>
<p>Product description - Dimension</p>	

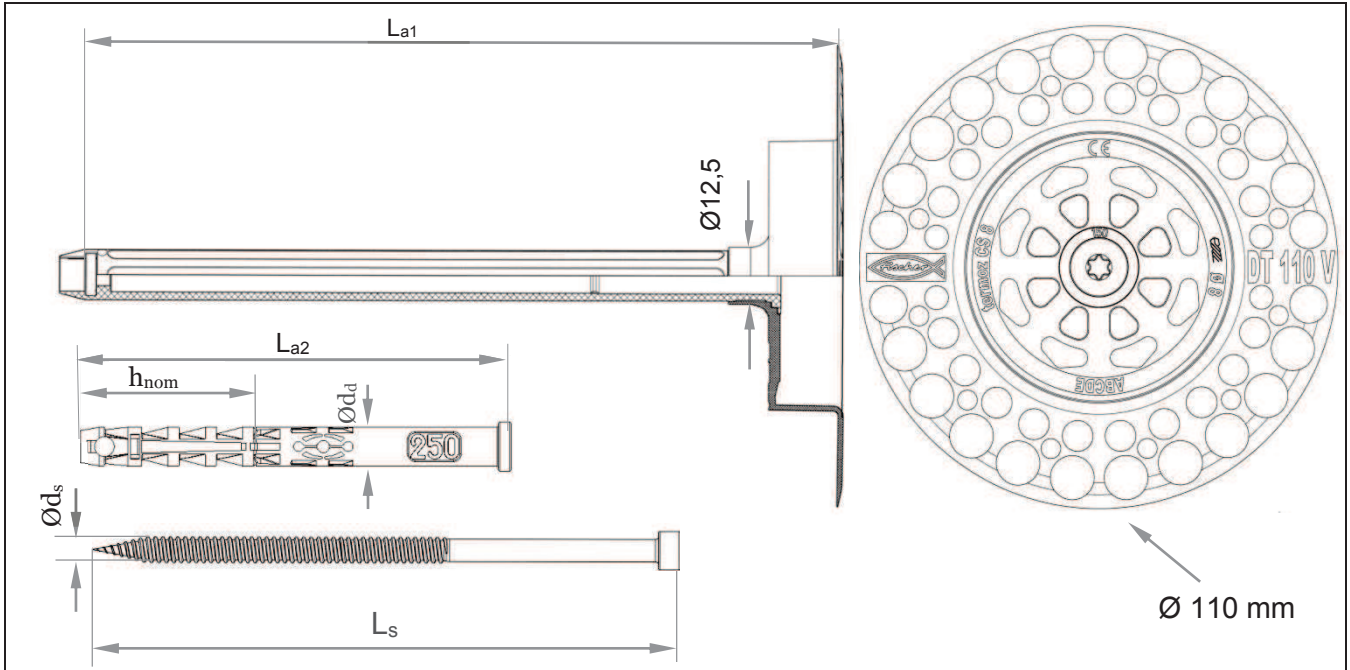

Setting tool with SDS adapter or hexagonal adapter available

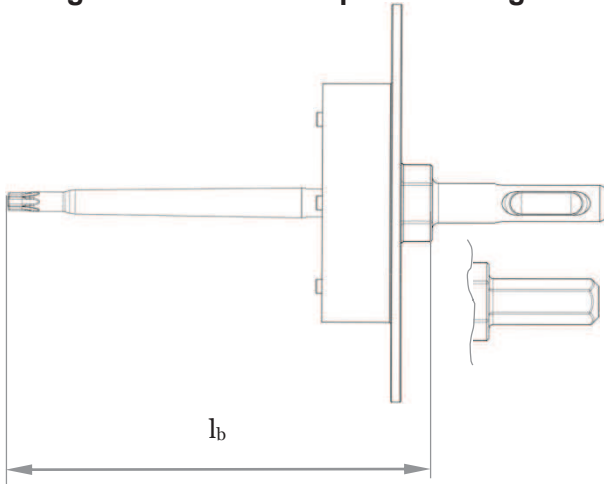

Polystyrene or mineral wool caps

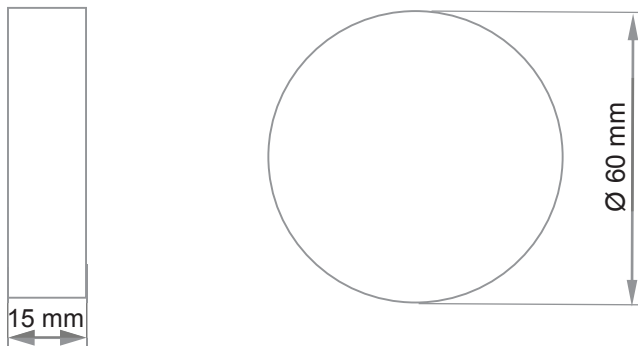



fischer termoz CS 8

Annex A7

Product description - Dimension

**Table A1: Slip-on plates, diameters and material**

	Designation
Name and size of anchor	termoz CS 8
Example	<b>fischer termoz CS 8</b>  (optional) <b>CE</b>  (optional) <b>Ø 8 ABCDE</b> (optional) and xxxxx additional marks possible

**Table A2: Dimensions [mm]**

Anchor type	Anchor sleeve		Shaft		Specific screw			Length of bits l <sub>b</sub>	
	Ø d <sub>d</sub>	h <sub>nom</sub>	L <sub>a</sub>	(L <sub>a1</sub> +L <sub>a2</sub> )	Ø d <sub>s</sub>	l <sub>s</sub>	Ø d <sub>1</sub>	l <sub>b</sub> [mm]	size
<b>termoz CS 8 110-230</b>	8	35	110-230	-	5,4	L <sub>a</sub>	8	30	T30
<b>termoz CS 8 250-390</b>	8	35	-	250-390	5,4	(L <sub>a1</sub> + L <sub>a2</sub> ) – 155mm	-	180	T25
<b>termoz CS 8 Renovation type 250-310</b>	8	35	-	250-310	5,4	(L <sub>a1</sub> + L <sub>a2</sub> ) – 75mm	-	100	T25

**Table A3: Dimensions [mm]**

Anchor type	Anchor sleeve		Shaft		Specific screw			Length of bits l <sub>b</sub>	
	Ø d <sub>d</sub>	h <sub>nom</sub>	L <sub>a</sub>	(L <sub>a1</sub> +L <sub>a2</sub> )	Ø d <sub>s</sub>	l <sub>s</sub>	Ø d <sub>1</sub>	l <sub>b</sub> [mm]	size
<b>termoz CS 8 DT110 V 130-230</b>	8	35	130-230	-	5,4	L <sub>a</sub>	8	30	T30
<b>termoz CS 8 DT110 V 250-390</b>	8	35	-	250-390	5,4	(L <sub>a1</sub> + L <sub>a2</sub> ) – 155mm	-	180	T25
<b>termoz CS 8 Renovation type DT110 V 250-310</b>	8	35	-	250-310	5,4	(L <sub>a1</sub> + L <sub>a2</sub> ) – 75mm	-	100	T25

**Table A4: Materials**

Designation	Material
Anchor sleeve	PP colour: grey
Shaft (termoz CS 8 / 250-390)	PA6 GF colour: grey
Specific compound screw (termoz CS 8 / 110-230) or specific screw (termoz CS 8 / 250-390)	PA6 GF with Steel gal Zn A2G or A2F acc. to EN ISO 4042 Steel gal Zn A2G or A2F according to EN ISO 4042 or stainless steel 1.4362 duplex coating, 1.4401, 1.4571, 1.4529 acc. to EN 10088
Anchor plate	PA6 GF colour: grey, blue, green, orange, red, yellow

<b>fischer termoz CS 8</b>	<b>Annex A8</b>
Product description – Dimension and materials	

## Drawing of the slip-on plates

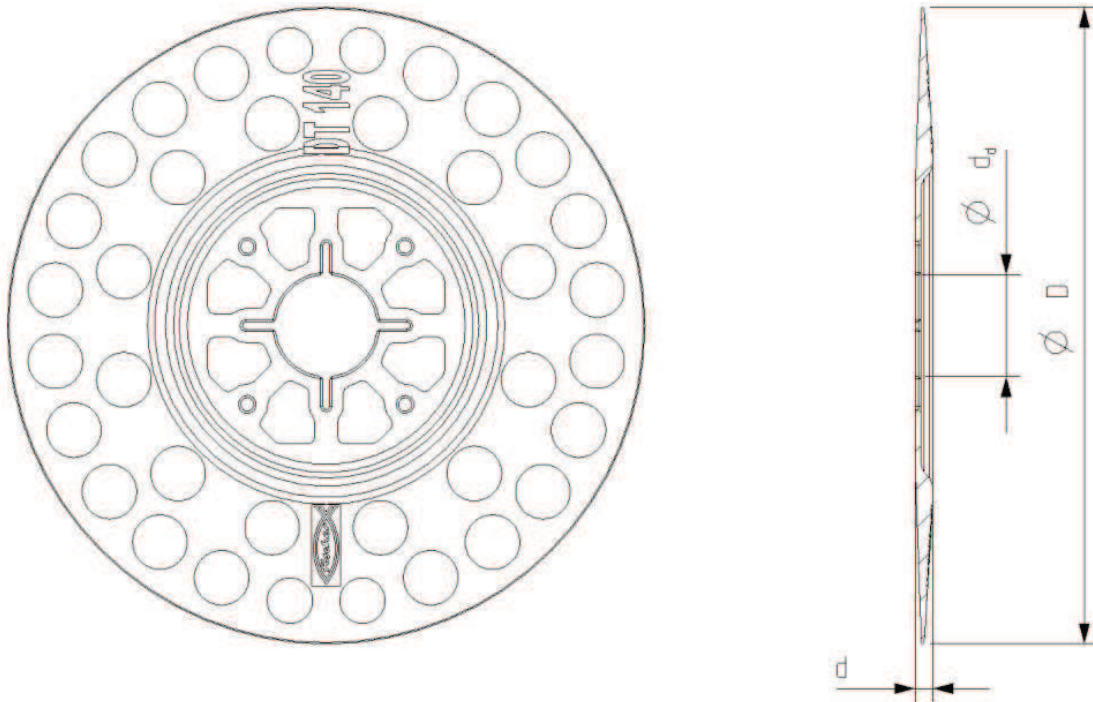

Table A4: Slip-on plates, diameters and material

Slip-on plate	Ø D [mm]	Ø d <sub>d</sub> [mm]	d [mm]	Material
DT 90 / 110 / 140	90 / 110 / 140	22,5	3,9	PA 6 GF

fischer termoz CS 8

Annex A9

Product description – Slip-on plates combined with termoz CS 8

### Specifications of intended use

**Anchorage subject to:**

- The anchor may only be used for transmission of wind suction loads and shall not be used for the transmission of dead loads of the thermal insulation composite system.

**Base materials:**

- Normal weight concrete (use category A) according to Annex C1.
- Solid masonry (use category B), according to Annex C1.
- Hollow or perforated masonry (use category C), according to Annex C1 and C2.
- Lightweight aggregate concrete (use category D), according to Annex C2
- Autoclaved aerated concrete (use category E), according to Annex C2
- For other base materials of the use categories A, B, C, D and E the characteristic resistance of the anchor may be determined by job site tests according to ETAG 014 Edition February 2011, Annex D.

**Temperature Range:**

- 0°C to +40°C (max. short term temperature +40°C and max. long term temperature +24°C).

**Design:**

- The anchorages are designed in accordance with ETAG 014 Edition February 2011 under the responsibility of an engineer experienced in anchorages and masonry work.
- Verifiable calculation notes and drawings are prepared taking account of the loads to be anchored. The position of the anchors is indicated on the design drawings.
- Fasteners are only to be used for multiple fixings for non-structural applications, according to ETAG 014 Edition February 2011.

**Installation:**

- Drilling method according to Annex C1 and C2.
- Anchor installation carried out by appropriately qualified personnel and under the supervision of the person responsible for technical matters on the site.
- Installation temperature from 0°C to +40°C
- Exposure to UV due to solar radiation of the anchor not protected by rendering ≤ 6 weeks.

<b>fischer termoz CS 8</b>	<b>Annex B1</b>
Intended use - Specifications	



**Table B1: Installation parameters for use categories A, B, C, D and E**

Anchor type	termoz CS 8		
		Flush	Countersunk
Nominal drill hole diameter	$d_0 = [\text{mm}]$	8	8
Cutting diameter of drill bit	$d_{\text{cut}} \leq [\text{mm}]$	8,45	8,45
Depth of drill hole to deepest point	$h_1 \geq [\text{mm}]$	45/55 <sup>*)</sup>	60/70 <sup>*)</sup>
Overall plastic anchor embedment depth in the base material	$h_{\text{nom}} \geq [\text{mm}]$	35/45 <sup>*)</sup>	35/45 <sup>*)</sup>

<sup>\*)</sup> only valid for weather shall acc. to Annex C1

**Table B2: Installation parameters for cat. "C" only valid for tested masonry units (see Table C1 Annex 1)**

Anchor type	termoz CS 8		
		Flush	Countersunk
Nominal drill hole diameter	$d_0 = [\text{mm}]$	8	8
Cutting diameter of drill bit	$d_{\text{cut}} \leq [\text{mm}]$	8,45	8,45
Depth of drill hole to deepest point	$h_1 \geq [\text{mm}]$	35	50
Overall plastic anchor embedment depth in the base material	$h_{\text{nom}} \geq [\text{mm}]$	25	25

**Table B3: Installation parameters alternative option for use category "E"**

Anchor type	termoz CS 8		
		Flush	Countersunk
Nominal drill hole diameter	$d_0 = [\text{mm}]$	8	8
Cutting diameter of drill bit	$d_{\text{cut}} \leq [\text{mm}]$	8,45	8,45
Depth of drill hole to deepest point	$h_1 \geq [\text{mm}]$	65	80
Overall plastic anchor embedment depth in the base material	$h_{\text{nom}} \geq [\text{mm}]$	55	55

**Table B4: Anchor distances and dimensions of members**

Anchor type		termoz CS 8
Minimum thickness of member	$h^{1)} \geq [\text{mm}]$	100
Minimum spacing	$s_{\text{min}} = [\text{mm}]$	100
Minimum edge distance	$c_{\text{min}} = [\text{mm}]$	100

1) not valid for weather shells acc. to C1

**Scheme of distances and spacing**

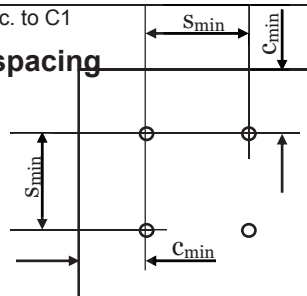

fischer termoz CS 8

Annex B2

Installation parameters for use categories

**Installation instructions**

**Standard setting of anchor (plain surface)**

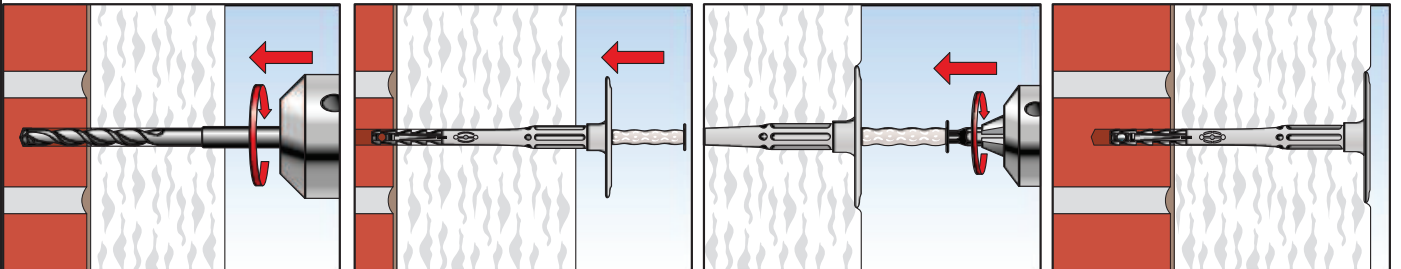

- 1. Drill hole by corresponding drilling method
- 2. Insert anchor manually
- 3. Set anchor by machine
- 4. Correctly installed anchor

**Setting of anchor (plain surface) by setting tool**

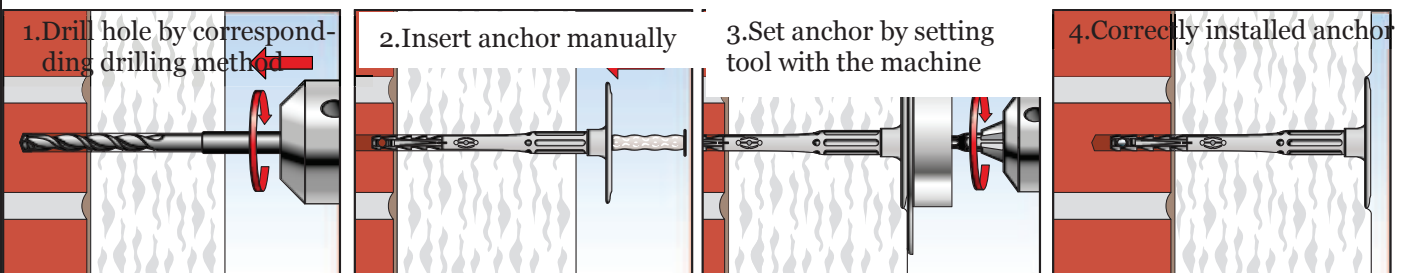

- 1. Drill hole by corresponding drilling method
- 2. Insert anchor manually
- 3. Set anchor by setting tool with the machine
- 4. Correctly installed anchor

**Setting of anchor (countersunk) by setting tool**

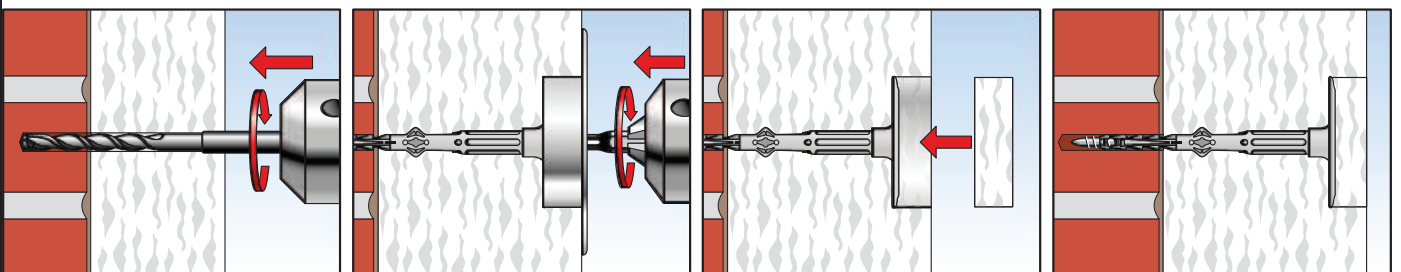

- 1. Drill hole by corresponding drilling method
- 2. Insert anchor and set anchor by setting tool
- 3. Put on polystyrene or mineral wool cap
- 4. Correctly installed anchor

**fischer termoz CS 8**

**Annex B3**

Procedure

**Table C1: Characteristic resistance to tension loads  $N_{Rk}$  in concrete and masonry for a single anchor in kN**

Base material	Bulk density class $\rho$ [kg/dm <sup>3</sup> ]	Minimum compressive strength $f_b$ [N/mm <sup>2</sup> ]	Remarks	Drill mode <sup>1)</sup>	Characteristic resistance termoz CS 8 $N_{Rk}$ [kN]
Concrete $\geq C 12/15$ and $< C 50/60$	-	-	EN 206-1:2000	H	1,2
Concrete C50/60					1,5
Weather resistant concrete shell $\geq C20/25$	-	-	EN 206-1:2000 ; $h \geq 42$ mm	H	1,2
Weather resistant concrete shell C 50/60	-	-	EN 206-1:2000 ; $h \geq 42$ mm		1,5
Solid Clay bricks e.g. acc. to DIN 105-100:2012-01, EN 771-1:2011, Mz	$\geq 1,8$	20	Cross section reduced up to 15% by perforation vertically to the resting area	H	1,5
Calcium silicate solid bricks, e.g. acc. to DIN V 106:2005-10, EN 771-2:2011, KS	$\geq 1,8$	20	Cross section reduced up to 15% by perforation vertically to the resting area	H	1,5
		12			0,9
Solid lightweight concrete block, e.g. acc. to DIN V 18152-100:2005-10 EN 771-3:2011 Vbl	$\geq 1,4$	8	Cross section reduced up to 15% by perforation vertically to the resting area	H	0,5
Solid concrete block, e.g. acc. to DIN V 18152-100:2005-10 EN 771-3:2011, Vbn	$\geq 2,0$	20	Cross section reduced up to 15% by perforation vertically to the resting area	H	1,2
		12			0,75
Vertically perforated clay bricks e.g. acc. to DIN 105-100:2012-01, EN 771-1:2011, HLz	$\geq 1,0$	12	Cross section reduced between 15% and 50% by perforation vertically to the resting area. Exterior web thickness $\geq 12$ mm	R	0,6
	$\geq 1,6$	48			1,5
Hollow calcium silicate brick, acc. to DIN V 106:2005-10, EN 771-2:2011, KSL	$\geq 1,4$	20	Cross section reduced between 15% and 50% by perforation vertically to the resting area. Exterior web thickness $\geq 23$ mm	H	0,9
		12			0,5
Partial safety factor				$\gamma_M^{2)}$	2,0

1) H = Hammer drilling, R = Rotary drilling

2) In absence of other national regulations

Cat. "C" values valid for reduced anchorage depth 25mm

<b>fischer termoz CS 8</b>	<b>Annex C1</b>
Intended use - Characteristic resistance of the anchor	

**Table C1:Char. resistance to tension loads  $N_{Rk}$  in masonry and aereated concrete for a single anchor in kN**

Base material	Bulk density class $\rho$ [kg/dm <sup>3</sup> ]	Minimum compressive strength $f_b$ [N/mm <sup>2</sup> ]	Remarks	Drill mode <sup>1)</sup>	Characteristic resistance termoz CS 8 $N_{Rk}$ [kN]
Hollow brick light-weight concrete, e.g. acc. to DIN V 18153-100: 2005-10, EN 771-3:2011 Hbl	$\geq 0,9$	4	Exterior web thickness $\geq 20$ mm	H	<b>0,5</b>
Hollow brick concrete, e.g. acc. to DIN V 18153-100: 2005-10, EN 771-3:2011 Hbn	$\geq 1,2$	10	Exterior web thickness $\geq 38$ mm	H	<b>1,2</b>
		8			<b>0,9</b>
		6			<b>0,75</b>
		4			<b>0,5</b>
Lightweight Aggregate Concrete $\geq$ LAC 6	$\geq 0,9$	6	DIN EN 1520	H	<b>0,75</b>
Autoclaved aerated concrete blocks, e.g. AAC acc. to DIN V 4165-100:2005-10, EN 771-4 $h_{nom} = 35$ mm	$\geq 0,50$	4	DIN V 4165-100	R	<b>0,3</b>
Autoclaved aerated concrete blocks, e.g. AAC acc. to DIN V 4165-100:2005-10, EN 771-4 $h_{nom} = 55$ mm					<b>0,6</b>
Partial safety factor				$\gamma_M^{2)}$	<b>2,0</b>

1) H = Hammer drilling, R = Rotary drilling

2) In absence of other national regulations

Cat "C" = values valid for reduced anchorage depth 25 mm

**Annex C2**

Performance - Characteristic resistance of the anchor

**Table C2: Point thermal transmittance acc. to EOTA Technical Report TR 025:2007-06**

Anchor type	Thickness of insulation material $h_D$ [mm]	Point thermal transmittance $\chi$ [W/K]
termoz CS 8 / 110 – 230 flush mounted	60 - 80	0,001
	100 - 180	0,002
termoz CS 8 / 250 – 390 flush mounted	200 - max.	0,001
termoz CS 8 / 250 - 310*) flush mounted	200 - 220	0,001
	240 - 260	0,002
termoz CS 8 / 110 – 230 countersunk mounted	80 - 120	0,001
	140 – 180	0,002
termoz CS 8 / 250 – 390 countersunk mounted	200 – max.	0,001
termoz CS 8 / 250 – 310 countersunk mounted*)	200 - 260	0,001

\*) Renovation type

**Table C3: Plate stiffness acc. to EOTA Technical Report TR 026:2007-06**

Anchor type	Max. size of the anchor plate [mm]	Load resistance of the anchor plate [kN]	Plate stiffness [kN/mm]
termoz CS 8	60	1,7	0,6

**Table C4: Displacements**

Base material	Tension load $F_{Rd}$ [kN]	Displacements $\delta_m$ [mm]
Concrete $\geq$ C12/15 (EN 206-1:2000)	0,40	< 0,3
Concrete C50/60 (EN 206-1:2000)	0,50	< 0,3
Weather resistant concrete shell $\geq$ C20/C25 (EN 206-1:2000)	0,40	< 0,4
Weather resistant concrete shell C50/60 (EN 206 1:2000)	0,50	< 0,4
Clay brick DIN 105-100:2012-01, EN 771-1:2011, Mz 20	0,50	< 0,3
Calcium silicate solid bricks DIN V 106:2005-10 EN 771-2 :2011,KS 20	0,50	< 0,3
Calcium silicate solid bricks DIN V 106:2005-10 EN 771-2 :2011,KS 12	0,30	
Solid lightweight concrete block DIN V 18152-100:2005-10 EN 771-3 :2011,Vbl 8	0,17	< 0,2

**fischer termoz CS 8**

**Annex C3**

Performance - Point thermal transmittance, plate stiffness and displacements

**Table C4.1: Displacements**

<b>Base material</b>	<b>Tension load <math>F_{Rd}</math> [kN]</b>	<b>Displacements <math>\delta_m</math> [mm]</b>
Solid concrete block DIN V 18152-100:2005-10 EN 771-3:2011,Vbn 20	0,40	< 0,3
Solid concrete block DIN V 18152-100:2005-10 EN 771-3:2011,Vbn 12	0,25	
Vertically perforated clay brick DIN 105-100:2012-01 EN 771-1:2011,Hlz 12	0,20	< 0,2
Vertically perforated clay brick DIN 105-100:2012-01 EN 771-1:2011,Hlz 48	0,50	< 0,3
Hollow calcium silicate brick DIN V 106:2005-10 EN 771-2:2011, KSL 20	0,30	< 0,2
Hollow calcium silicate brick DIN V 106:2005-10 EN 771-2:2011, KSL 12	0,17	
Hollow brick light-weight concrete DIN V 18153-100: 2005-10 EN 771-3:2011, Hbl 4	0,17	< 0,1
Hollow brick concrete DIN V 18153-100: 2005-10 EN 771-3:2011, Hbn 10	0,40	< 0,2
Hollow brick concrete DIN V 18153-100: 2005-10 EN 771-3:2011, Hbn 8	0,30	
Hollow brick concrete DIN V 18153-100: 2005-10 EN 771-3:2011, Hbn 6	0,25	
Hollow brick concrete DIN V 18153-100: 2005-10 EN 771-3:2011, Hbn 4	0,17	
Lightweight Aggregate Concrete $\geq$ LAC 6 DIN EN 1520	0,25	< 0,2
Autoclaved aerated concrete blocks DIN V 4165-100:2005-10 EN 771-4, AAC 4, $h_{nom} = 35$ mm	0,10	< 0,1
Autoclaved aerated concrete blocks DIN V 4165-100:2005-10 EN 771-4, AAC 4, $h_{nom} = 55$ mm	0,20	< 0,1

fischer termoz CS 8

Annex C4

Performance - Displacements