

## PROHLÁŠENÍ O VLASTNOSTECH

### DoP 0191

pro pro vstřikovací systém fischer Superbond (Kovové kotvy do betonu)

CS

1. <u>Jedinečný identifikační kód typu výrobku:</u>	<b>DoP 0191</b>		
2. <u>Zamýšlené/zamýšlená použití:</u>	<b>Dodatečné upevnění v tažené a tlačené zóně betonu.</b>		
3. <u>Výrobce:</u>	<b>Viz. dodatek, obzvláště Přílohy B1- B15</b>		
	<b>fischerwerke GmbH &amp; Co. KG, Otto-Hahn-Straße 15, 79211 Denzlingen, Německo</b>		
4. <u>Zplnomocněný zástupce:</u>	–		
5. <u>Systém/systémy POSV:</u>	1		
6. <u>Evropský dokument pro posuzování:</u>	<b>EAD 330499-01-0601</b>		
Evropské technické posouzení:	<b>ETA-12/0258; 2020-06-17</b>		
Subjekt pro technické posuzování:	<b>DIBt- Deutsches Institut für Bautechnik</b>		
Oznámený subjekt/oznámené subjekty:	<b>1343 MPA Darmstadt / 2873 TU Darmstadt</b>		
7. <u>Deklarovaná vlastnost/Deklarované vlastnosti:</u>			
<b>Mechanická odolnost a stabilita (BWR 1)</b>			
Charakteristická únosnost v tahu (pro statickou a kvazistatickou akci):	Odolnost proti selhání oceli: Odolnost proti kombinovanému porušení vytažením a selháním betonu: Odolnost proti selhání betonu: Okrajová vzdálenost bránící rozštěpení při zatížení:	Přílohy C1- C3 Přílohy C4- C10 Přílohy C4 Přílohy C4	$\tau_{Rk,100} =$ NPD
	Pevnost: Maximální utahovací moment při instalaci:	Přílohy C4-C10, C15, C16 Přílohy B4- B8	
	Minimální vzdálenost od okraje a rozteč:	Přílohy B4- B8	
Charakteristická únosnost ve smyku (pro statickou a kvazistatickou akci):	Odolnost proti selhání oceli: Odolnost proti selhání rozštěpením: Odolnost proti selhání okraje betonu:	Přílohy C1- C3 Přílohy C4 Přílohy C4	
Charakteristická únosnost a posuny pro seismické kategorie C1 a C2:	Odolnost proti tahovému zatížení, posuny, kategorie C1: Odolnost proti tahovému zatížení, posuny, kategorie C2: Odolnost proti smykovému zatížení, posuny, kategorie C1: Odolnost proti smykovému zatížení, posuny, kategorie C2: Koeficient prstencové mezery:	Přílohy C13, C14, C15 Přílohy C13, C14, C16 Přílohy C13, C14 Přílohy C13, C14, C16 Přílohy C13	
posuny při krátkodobém a dlouhodobém zatížení:	Posuny při krátkodobém a dlouhodobém zatížení:	Přílohy C11- C12	
<b>Hygiena, zdraví a životní prostředí (BWR 3)</b>			
Obsah, emise a / nebo uvolňování nebezpečných látek:	NPA		



8. Příslušná technická dokumentace a/nebo specifická technická dokumentace: -

Vlastnosti výše uvedeného výrobku jsou ve shodě se souborem deklarovaných vlastností. Toto prohlášení o vlastnostech se v souladu s nařízením (EU) č. 305/2011 vydává na výhradní odpovědnost výrobce uvedeného výše.

Podepsáno za výrobce a jeho jménem:

Thilo Pregartner, Dr.-Ing.  
Tumlingen, 2020-07-01

Peter Schillinger, Dipl.-Ing.

Toto PoV bylo připraveno v různých jazykových mutacích. V případě rozporu vždy rozhoduje interpretace verze v anglickém jazyce.

Příloha obsahuje nepovinné a doplňkové informace v anglickém jazyce nad rámec zákonných požadavků.

## Specific Part

### 1 Technical description of the product

The injection system fischer Superbond is a bonded anchor for use in concrete consisting of a cartridge with injection mortar fischer FIS SB or a resin capsule fischer RSB and a steel element according to Annex A 5.

The steel element is placed into a drilled hole filled with injection mortar and is anchored via the bond between metal part, injection mortar and concrete.

The resin capsule is placed into the hole and the steel element is driven by machine with simultaneous hammering and turning. The anchor rod is anchored via the bond between steel element, chemical mortar and concrete

The product description is given in Annex A.

### 2 Specification of the intended use in accordance with the applicable European Assessment Document

The performances given in Section 3 are only valid if the anchor is used in compliance with the specifications and conditions given in Annex B.

The verifications and assessment methods on which this European Technical Assessment is based lead to the assumption of a working life of the anchor of at least 50 years. The indications given on the working life cannot be interpreted as a guarantee given by the producer, but are to be regarded only as a means for choosing the right products in relation to the expected economically reasonable working life of the works.

### 3 Performance of the product and references to the methods used for its assessment

#### 3.1 Mechanical resistance and stability (BWR 1)

Essential characteristic	Performance
Characteristic resistance to tension load (static and quasi-static loading)	See Annex B 4 to B 8, C 1 to C 10
Characteristic resistance to shear load (static and quasi-static loading)	See Annex C 1 to C 4
Displacements under short-term and long-term loading	See Annex C 11 and C 12
Characteristic resistance and displacements for seismic performance categories C1 and C2	See Annex C 13 to C 16

#### 3.2 Hygiene, health and the environment (BWR 3)

Essential characteristic	Performance
Content, emission and/or release of dangerous substances	No performance assessed

**4 Assessment and verification of constancy of performance (AVCP) system applied, with reference to its legal base**

In accordance with the European Assessment Document EAD 330499-01-0601 the applicable European legal act is: [96/582/EC].

The system to be applied is: 1

# Installation conditions part 1

anchor rod or fischer anchor rod RG M with fischer injection system FIS SB

**Pre-positioned installation**

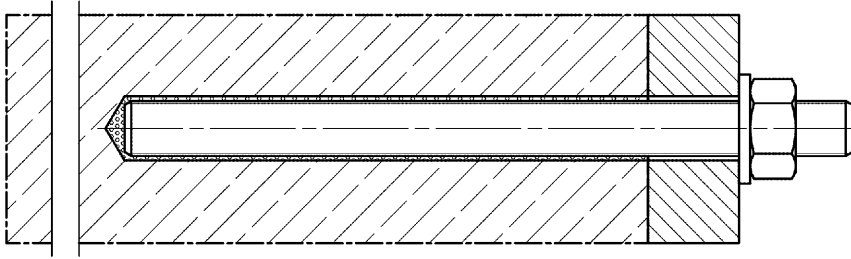

**Push through installation** (annular gap filled with mortar)

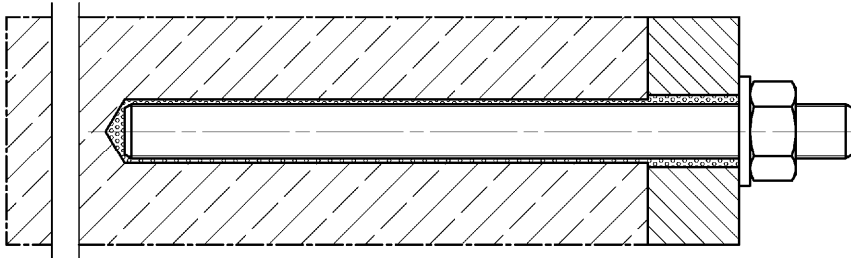

**Pre-positioned or push through installation with subsequently injected fischer filling disc**  
(annular gap filled with mortar)

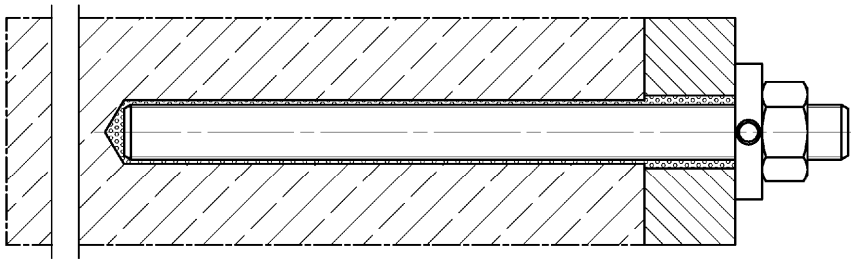

Figures not to scale

fischer Superbond

**Product description**  
Installation conditions part 1

**Annex A 1**

Appendix 3/ 40

## Installation conditions part 2

### Reinforcing bar with fischer injection system FIS SB

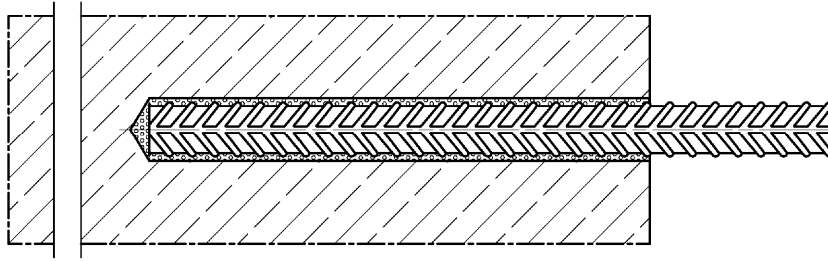

### fischer rebar anchor FRA with fischer injection system FIS SB

#### Pre-positioned installation

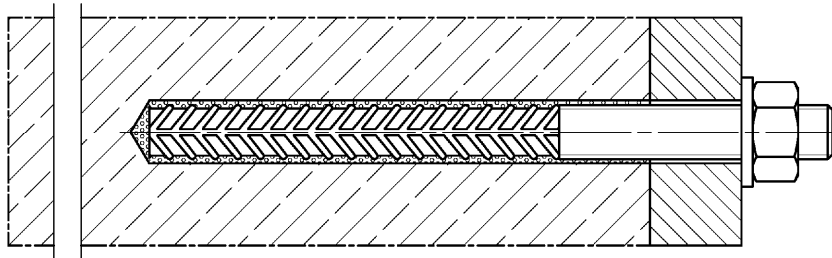

#### Push through installation (annular gap filled with mortar)

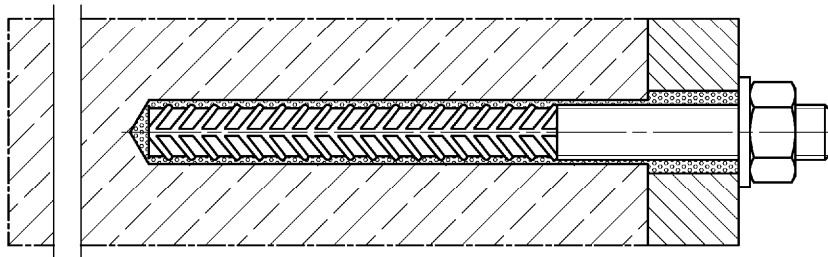

Figures not to scale

fischer Superbond

**Product description**  
Installation conditions part 2

**Annex A 2**

Appendix 4/ 40

### Installation conditions part 3

fischer internal threaded anchor RG MI with fischer resin capsule system RSB or fischer injection system FIS SB

Pre-positioned installation

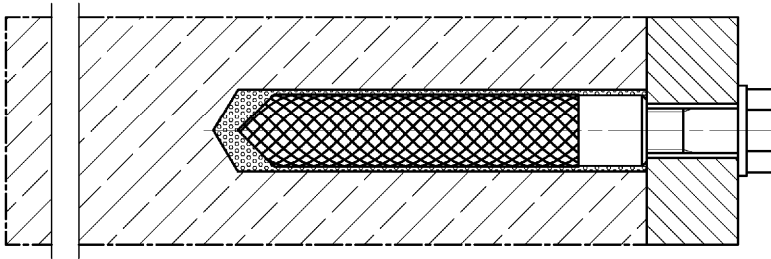

Pre-positioned installation with subsequently injected fischer filling disc (annular gap filled with mortar)

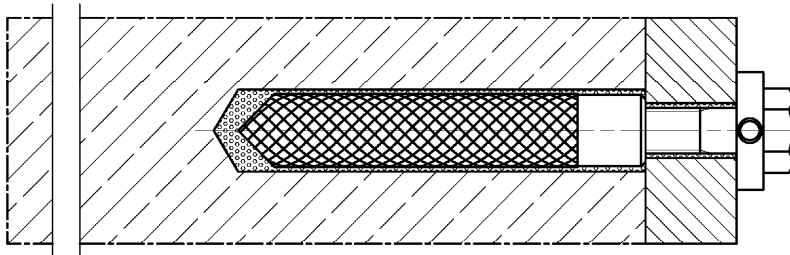

fischer anchor rod RG M with fischer resin capsule system RSB

Pre-positioned installation

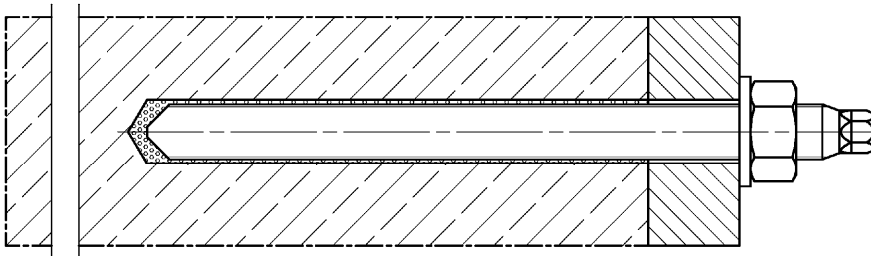

Pre-positioned installation with subsequently injected fischer filling disc (annular gap filled with mortar)

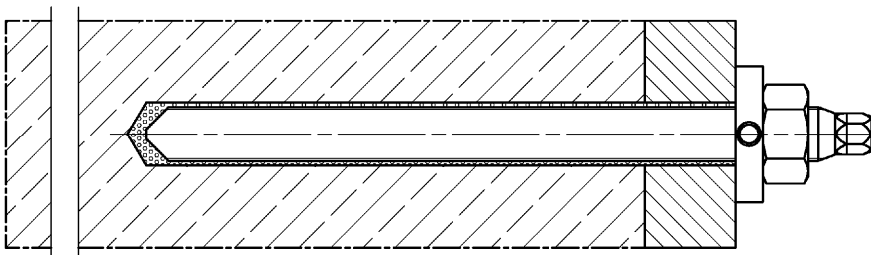

Figures not to scale

fischer Superbond

**Product description**  
Installation conditions part 3

**Annex A 3**

Appendix 5/ 40

## Overview system components Part 1

**Mortar cartridge (shuttle cartridge) with sealing cap; Sizes: 390 ml, 585 ml, 1100 ml, 1500 ml**

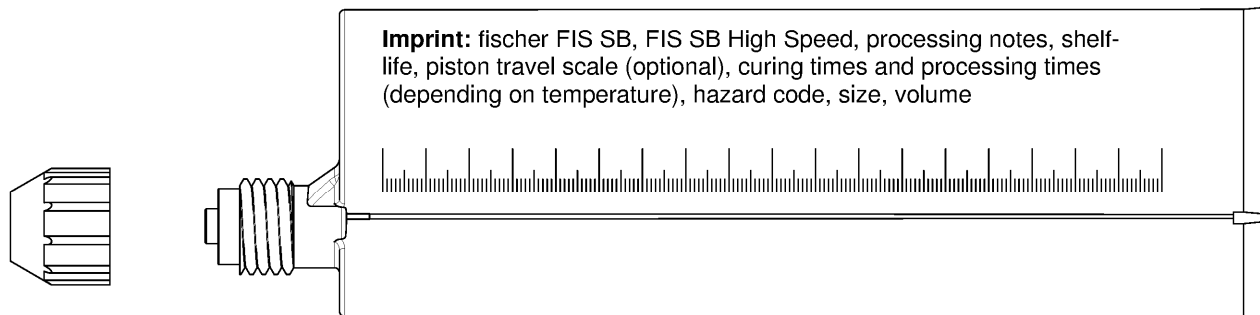

**Resin capsule**

Sizes: 8, 10 mini, 10, 12 mini, 12, 16 mini, 16, 16 E, 20, 20 E / 24, 30



**Static mixer FIS MR Plus or UMR**

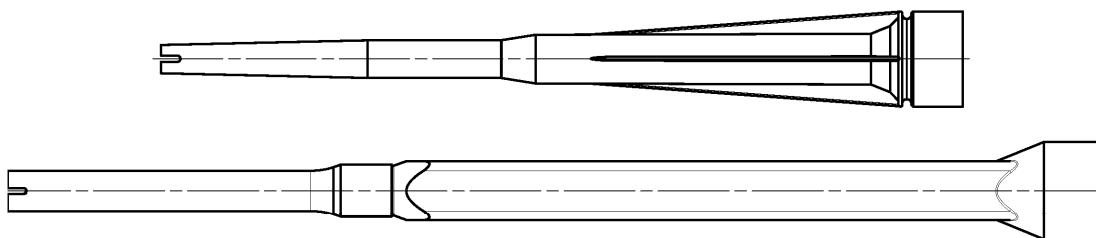

**Injection adapter / extension tube for static mixer**

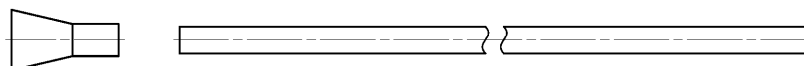

Figures not to scale

fischer Superbond

**Product description**

Overview system components part 1;  
cartridges / capsule / static mixer / injection adapter

**Annex A 4**

Appendix 6/ 40



## Overview system components Part 2

### anchor rod

Sizes: M8, M10, M12, M16, M20, M24, M27, M30

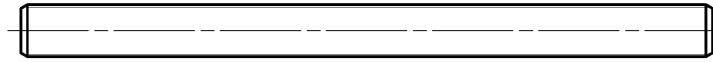

### fischer anchor rod RG M

Sizes: M8, M10, M12, M16, M20, M24, M30

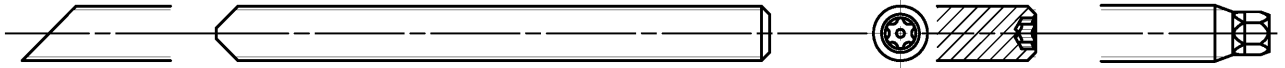

### fischer internal threaded anchor RG MI

Size: M8, M10, M12, M16, M20

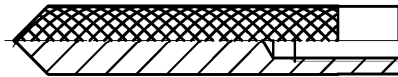

### Screw / threaded rod / washer / hexagon nut

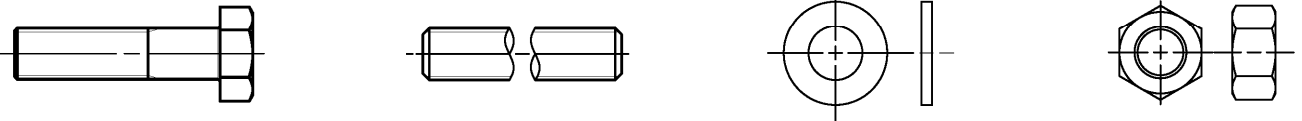

### fischer filling disc with injection adapter

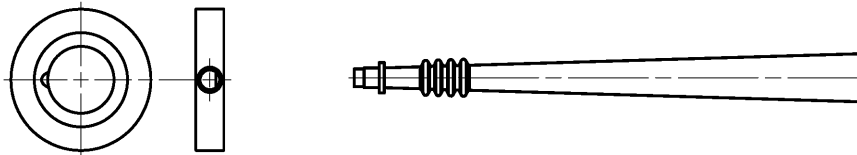

### Reinforcing bar

Nominal diameters:  $\phi 8$ ,  $\phi 10$ ,  $\phi 12$ ,  $\phi 14$ ,  $\phi 16$ ,  $\phi 20$ ,  $\phi 25$ ,  $\phi 28$ ,  $\phi 32$



### fischer rebar anchor FRA

Sizes: M12, M16, M20, M24



Figures not to scale

fischer Superbond

#### Product description

Overview system components part 2;  
steel components

**Annex A 5**

Appendix 7 / 40

## Overview system components Part 3

### Cleaning brush BS / BSB



### Blow-out pump ABG or ABP with cleaning nozzle



Figures not to scale

fischer Superbond

#### Product description

Overview system components part 3;  
cleaning brush / blow-out pump / injection adapter

**Annex A 6**

Appendix 8/ 40

**Table A7.1: Materials**

Part	Designation	Material		
1	Injection cartridge	Mortar, hardener, filler		
	Steel grade	Steel	Stainless steel R	High corrosion resistant steel HCR <sup>2)</sup>
		zinc plated	acc. to EN 10088-1:2014 Corrosion resistance class CRC III acc. to EN 1993-1-4:2015	acc. to EN 10088-1:2014 Corrosion resistance class CRC V acc. to EN 1993-1-4:2015
2	Anchor rod	Property class 4.8, 5.8 or 8.8; EN ISO 898-1:2013 zinc plated $\geq 5 \mu\text{m}$ , ISO 4042:2018/Zn5/An(A2K) or hot dip galvanised $\geq 40 \mu\text{m}$ EN ISO 10684:2004 $f_{uk} \leq 1000 \text{ N/mm}^2$ $A_5 > 12\%$ fracture elongation	Property class 50, 70 or 80 EN ISO 3506-1:2009 1.4401; 1.4404; 1.4578; 1.4571; 1.4439; 1.4362; 1.4062, 1.4662, 1.4462; EN 10088-1:2014 $f_{uk} \leq 1000 \text{ N/mm}^2$ $A_5 > 12\%$ fracture elongation	Property class 50 or 80 EN ISO 3506-1:2009 or property class 70 with $f_{yk} = 560 \text{ N/mm}^2$ 1.4565; 1.4529; EN 10088-1:2014 $f_{uk} \leq 1000 \text{ N/mm}^2$ $A_5 > 12\%$ fracture elongation
		Fracture elongation $A_5 > 8\%$ , for applications without requirements for seismic performance category C2		
3	Washer ISO 7089:2000	zinc plated $\geq 5 \mu\text{m}$ , ISO 4042:2018/Zn5/An(A2K) or hot dip galvanised $\geq 40 \mu\text{m}$ EN ISO 10684:2004	1.4401; 1.4404; 1.4578; 1.4571; 1.4439; 1.4362; EN 10088-1:2014	1.4565; 1.4529; EN 10088-1:2014
4	Hexagon nut	Property class 5 or 8; EN ISO 898-2:2012 zinc plated $\geq 5 \mu\text{m}$ , ISO 4042:2018/Zn5/An(A2K) or hot dip galvanised $\geq 40 \mu\text{m}$ EN ISO 10684:2004	Property class 50, 70 or 80 EN ISO 3506-1:2009 1.4401; 1.4404; 1.4578; 1.4571; 1.4439; 1.4362; EN 10088-1:2014	Property class 50, 70 or 80 EN ISO 3506-1:2009 1.4565; 1.4529 EN 10088-1:2014
5	fischer internal threaded anchor RG MI	Property class 5.8 ISO 898-1:2013 zinc plated $\geq 5 \mu\text{m}$ , ISO 4042:2018/Zn5/An(A2K)	Property class 70 EN ISO 3506-1:2009 1.4401; 1.4404; 1.4578; 1.4571; 1.4439; 1.4362; EN 10088-1:2014	Property class 70 EN ISO 3506-1:2009 1.4565; 1.4529; EN 10088-1:2014
6	Commercial standard screw or threaded rod for fischer internal threaded anchor RG MI	Property class 5.8 or 8.8; EN ISO 898-1:2013 zinc plated $\geq 5 \mu\text{m}$ , ISO 4042:2018/Zn5/An(A2K), $A_5 > 8\%$ fracture elongation	Property class 70 EN ISO 3506-1:2009 1.4401; 1.4404; 1.4578; 1.4571; 1.4439; 1.4362; EN 10088-1:2014 $A_5 > 8\%$ fracture elongation	Property class 70 EN ISO 3506-1:2009 1.4565; 1.4529; EN 10088-1:2014 $A_5 > 8\%$ fracture elongation
7	fischer filling disc similar to DIN 6319-G	zinc plated $\geq 5 \mu\text{m}$ , ISO 4042:2018/Zn5/An(A2K) or hot dip galvanised $\geq 40 \mu\text{m}$ EN ISO 10684:2004	1.4401; 1.4404; 1.4578; 1.4571; 1.4439; 1.4362; EN 10088-1:2014	1.4565; 1.4529; EN 10088-1:2014
8	Reinforcing bar EN 1992-1-1:2004 and AC:2010, Annex C	Bars and de-coiled rods, class B or C with $f_{yk}$ and $k$ according to NDP or NCL according to EN 1992-1-1/NA $f_{uk} = f_{tk} = k \cdot f_{yk}$		
9	fischer rebar anchor FRA	Rebar part: Bars and de-coiled rods class B or C with $f_{yk}$ and $k$ according to NDP or NCL of EN 1992-1-1:2004+AC:2010 $f_{uk} = f_{tk} = k \cdot f_{yk}$	Threaded part: Property class 70 or 80 EN ISO 3506-1:2009 1.4401, 1.4404, 1.4571, 1.4578, 1.4439, 1.4362, 1.4062 acc. to EN 10088-1:2014 Corrosion resistance class CRC III acc. to EN 1993-1-4:2015 1.4565; 1.4529 acc. to EN 10088-1:2014 Corrosion resistance class CRC V acc. to EN 1993-1-4:2015	







fischer Superbond

**Product description**  
Materials
**Annex A 7**

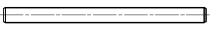
Appendix 9/ 40

# Specifications of intended use (part 1)

**Table B1.1:** Overview use and performance categories, injection mortar system FIS SB

Anchorages subject to		FIS SB with ...							
		anchor rod 	fischer internal threaded anchor RG MI 	Reinforcing bar 	fischer rebar anchor FRA 				
Hammer drilling with standard drill bit 		all sizes							
Hammer drilling with hollow drill bit (fischer "FHD", Heller "Duster Expert"; Bosch „Speed Clean“; Hilti "TE-CD, TE-YD", DreBo „D-Plus“, DreBo „D-Max“) 		Nominal drill bit diameter (d <sub>0</sub> ) 12 mm to 35 mm							
Diamond drilling 		not permitted							
Static and quasi static load, in	uncracked concrete	all sizes	Tables: C1.1 C4.1 C5.1 C11.1	all sizes	Tables: C2.1 C4.1 C7.1 C11.2	all sizes	Tables: C3.1 C4.1 C9.1 C12.1	all sizes	Tables: C3.2 C4.1 C10.1 C12.2
	cracked concrete								
Seismic performance category (only hammer drilling with standard / hollow drill bits)	C1	all sizes	Tables: C13.1 C14.2 C15.1	_1)		all sizes	Tables: C14.1 C14.2 C15.2		_1)
	C2		M12 M16 M20 M24				Tables: C13.1 C14.2 C16.1		
Use category	I1 dry or wet concrete	all sizes							
	I2 water filled hole	not permitted							
Installation direction	D3 (downward and horizontal and upwards (overhead) installation)								
Installation method	pre-positioned or push through installation								
Installation temperature	FIS SB: T <sub>i,min</sub> = -15 °C to T <sub>i,max</sub> = +40 °C FIS SB High Speed: T <sub>i,min</sub> = -20 °C to T <sub>i,max</sub> = +40 °C								
In-service temperature	Temperature range I	-40 °C to +40 °C		T <sub>st</sub> = +40 °C / T <sub>lt</sub> = +24 °C					
	Temperature range II	-40 °C to +80 °C		T <sub>st</sub> = +80 °C / T <sub>lt</sub> = +50 °C					
	Temperature range III	-40 °C to +120 °C		T <sub>st</sub> = +120 °C / T <sub>lt</sub> = +72 °C					
	Temperature range IV	-40 °C to +150 °C		T <sub>st</sub> = +150 °C / T <sub>lt</sub> = +90 °C					

<sup>1)</sup> No performance assessed

fischer Superbond





**Intended use**  
Specifications (part 1), fischer injection mortar system FIS SB

**Annex B 1**

Appendix 10/ 40

## Specifications of intended use (part 2)

**Table B2.1:** Overview use and performance categories, **resin capsule system RSB**

Anchorages subject to		RSB with ...			
		fischer anchor rod RG M 	fischer internal threaded anchor RG MI 		
Hammer drilling with standard drill bit 		all sizes			
Hammer drilling with hollow drill bit (fischer "FHD", Heller "Duster Expert"; Bosch "Speed Clean"; Hilti "TE-CD, TE-YD", DreBo "D-Plus", DreBo "D-Max") 		Nominal drill bit diameter ( $d_0$ ) 12 mm to 35 mm	all sizes		
Diamond drilling 		all sizes <sup>1)</sup>			
Static and quasi static load, in	uncracked concrete	all sizes	Tables: C1.1 C4.1 C6.1 C11.1	all sizes	Tables: C2.1 C4.1 C8.1 C11.2
	cracked concrete	all sizes <sup>1)</sup>		all sizes <sup>1)</sup>	
Seismic performance category (only hammer drilling with standard / hollow drill bits)	C1	all sizes	Tables: C13.1 C14.2 C15.1	_2)	
	C2	_2)			
Use category	I1 dry or wet concrete	all sizes			
	I2 water filled hole	all sizes			
Installation direction	D3 (downward and horizontal and upwards (overhead) installation)				
Installation method	only pre-positioned installation				
Installation temperature	$T_{i,min} = -30\text{ °C}$ to $T_{i,max} = +40\text{ °C}$				
In-service temperature	Temperature range I	-40 °C to +40 °C	$T_{st} = +40\text{ °C}$ / $T_{lt} = +24\text{ °C}$		
	Temperature range II	-40 °C to +80 °C	$T_{st} = +80\text{ °C}$ / $T_{lt} = +50\text{ °C}$		
	Temperature range III	-40 °C to +120 °C	$T_{st} = +120\text{ °C}$ / $T_{lt} = +72\text{ °C}$		
	Temperature range IV	-40 °C to +150 °C	$T_{st} = +150\text{ °C}$ / $T_{lt} = +90\text{ °C}$		

<sup>1)</sup> For diamond drilling in cracked concrete only nominal drill bit diameters ( $d_0$ )  $\geq 18$  mm are permitted

<sup>2)</sup> No performance assessed

fischer Superbond

**Intended use**  
Specifications (part 2), fischer resin capsule system RSB

**Annex B 2**

Appendix 11/ 40

## Specifications of intended use (part 3)

### Base materials:

- Compacted reinforced or unreinforced normal weight concrete without fibres of strength classes C20/25 to C50/60 according to EN 206:2013+A1:2016

### Use conditions (Environmental conditions):

- Structures subject to dry internal conditions (zinc coated steel, stainless steel or high corrosion resistant steel).
- For all other conditions according to EN1993-1-4:2015 corresponding to corrosion resistance classes to Annex A 7 table A7.1.

### Design:

- Anchorages have to be designed by a responsible engineer with experience of concrete anchor design.
- Verifiable calculation notes and drawings are to be prepared taking account of the loads to be anchored. The position of the anchor is indicated on the design drawings (e. g. position of the anchor relative to reinforcement or to supports, etc.).
- Anchorages are designed in accordance with: EN 1992-4:2018 and EOTA Technical Report TR 055, Edition February 2018.

### Installation:

- Anchor installation is to be carried out by appropriately qualified personnel and under the supervision of the person responsible for technical matters of the site
- In case of aborted hole: The hole shall be filled with mortar
- Anchorage depth should be marked and adhered to on installation
- Overhead installation is allowed

fischer Superbond

**Intended use**  
Specifications (part 3)

**Annex B 3**

Appendix 12/ 40

**Table B4.1: Installation parameters for anchor rods in combination with injection mortar system FIS SB**

Anchor rods		Thread	M8	M10	M12	M16	M20	M24	M27	M30
Width across flats	SW	[mm]	13	17	19	24	30	36	41	46
Nominal drill hole diameter	$d_0$		10	12	14	18	24	28	30	35
Drill hole depth	$h_0$		$h_0 = h_{ef}$							
Effective embedment depth	$h_{ef, min}$		60	60	70	80	90	96	108	120
	$h_{ef, max}$		160	200	240	320	400	480	540	600
Minimum spacing and minimum edge distance	$s_{min}$ =		40	45	55	65	85	105	120	140
	$c_{min}$									
Diameter of the clearance hole of the fixture	pre-positioned installation $d_f$		9	12	14	18	22	26	30	33
	push through installation $d_f$		11	14	16	20	26	30	33	40
Min. thickness of concrete member	$h_{min}$		$h_{ef} + 30$ ( $\geq 100$ )				$h_{ef} + 2d_0$			
Maximum setting torque	$\max T_{inst}$	[Nm]	10	20	40	60	120	150	200	300

**fischer anchor rod**



**Marking (on random place) fischer anchor rod:**

Steel zinc plated PC <sup>1)</sup> 8.8	• or +	Steel hot-dip PC <sup>1)</sup> 8.8	•
High corrosion resistant steel HCR PC <sup>1)</sup> 50	•	High corrosion resistant steel HCR PC <sup>1)</sup> 70	-
High corrosion resistant steel HCR PC <sup>1)</sup> 80	(	Stainless steel R property class 50	~
Stainless steel R property class 80	*		

Alternatively: Colour coding according to DIN 976-1:2016 <sup>1)</sup> PC = property class

**Installation conditions:**

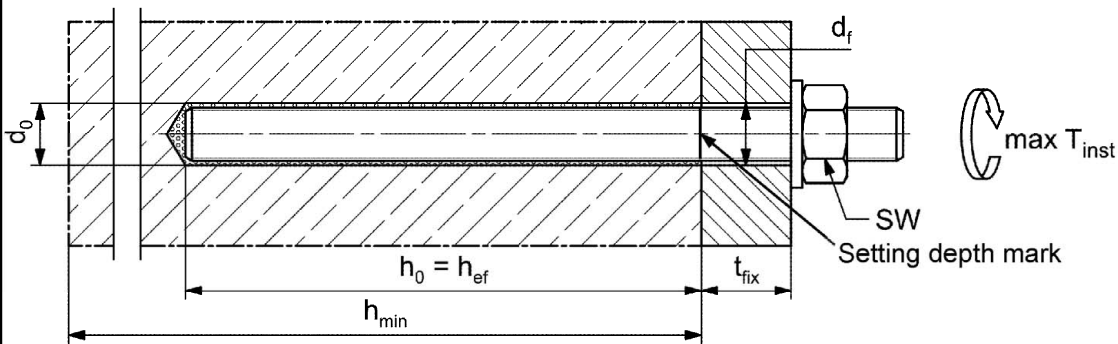

**Commercial standard threaded rods, washers and hexagon nuts may also be used if the following requirements are fulfilled:**

- Materials, dimensions and mechanical properties according to Annex A 7, Table A7.1
- Inspection certificate 3.1 according to EN 10204:2004, the documents have to be stored
- Setting depth is marked

Figures not to scale

fischer Superbond

**Intended use**

Installation parameters for anchor rods in combination with injection mortar system FIS SB

**Annex B 4**

Appendix 13/ 40

**Table B5.1: Installation parameters for fischer anchor rods RG M in combination with resin capsule system RSB**

Anchor rod RG M		Thread	M8	M10	M12	M16	M20	M24	M30	
Width across flats	SW	[mm]	13	17	19	24	30	36	46	
Nominal drill hole diameter	$d_0$		10	12	14	18	25	28	35	
Drill hole depth	$h_0$		$h_0 = h_{ef}$							
Effective embedment depth	$h_{ef,1}$		---	75	75	95	---	---	---	
	$h_{ef,2}$		80	90	110	125	170	210	280	
	$h_{ef,3}$		---	150	150	190	210	---	---	
Minimum spacing and minimum edge distance	$s_{min} = c_{min}$		40	45	55	65	85	105	140	
Diameter of the pre-positioned clearance hole of the fixture installation	$d_f$		9	12	14	18	22	26	33	
Min. thickness of concrete member	$h_{min}$		$h_{ef} + 30$ ( $\geq 100$ )			$h_{ef} + 2d_0$				
Maximum setting torque	$\max T_{inst}$		[Nm]	10	20	40	60	120	150	300

**fischer anchor rod RG M**

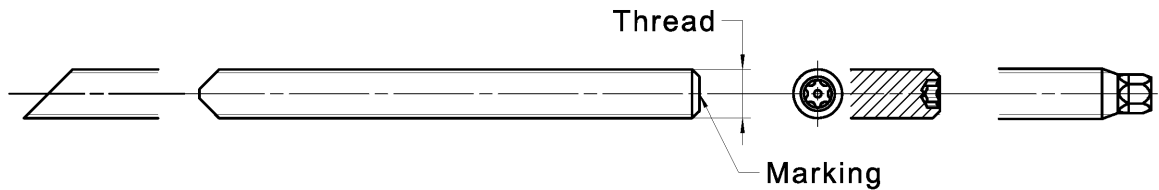

**Marking (on random place) fischer anchor rod RG M:**

Steel zinc plated PC <sup>1)</sup> 8.8	• or +	Steel hot-dip PC <sup>1)</sup> 8.8	•
High corrosion resistant steel HCR PC <sup>1)</sup> 50	•	High corrosion resistant steel HCR PC <sup>1)</sup> 70	-
High corrosion resistant steel HCR PC <sup>1)</sup> 80	(	Stainless steel R property class 50	~
Stainless steel R property class 80	*		
Alternatively: Colour coding according to DIN 976-1:2016			<sup>1)</sup> PC = property class

**Installation conditions:**

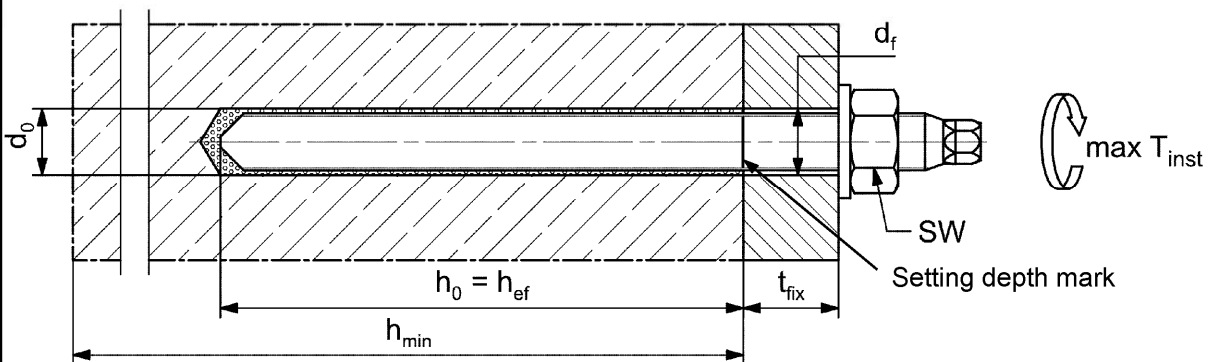

Figures not to scale

fischer Superbond

**Intended use**

Installation parameters for fischer anchor rods RG M in combination with resin capsule system RSB

**Annex B 5**

Appendix 14/ 40



**Table B6.1:** Installation parameters for **fischer internal threaded anchors RG MI**

Internal threaded anchor RG MI		Thread	M8	M10	M12	M16	M20
Sleeve diameter	$d = d_H$	[mm]	12	16	18	22	28
Nominal drill hole diameter	$d_0$		14	18	20	24	32
Drill hole depth	$h_0$		$h_0 = h_{ef} = L_H$				
Effective embedment depth ( $h_{ef} = L_H$ )	$h_{ef}$		90	90	125	160	200
Minimum spacing and minimum edge distance	$s_{min}$ = $c_{min}$		55	65	75	95	125
Diameter of clearance hole in the fixture	$d_f$		9	12	14	18	22
Minimum thickness of concrete member	$h_{min}$		120	125	165	205	260
Maximum screw-in depth	$l_{E,max}$		18	23	26	35	45
Minimum screw-in depth	$l_{E,min}$		8	10	12	16	20
Maximum installation torque	$\max T_{inst}$		[Nm]	10	20	40	80

**fischer internal threaded anchor RG MI**

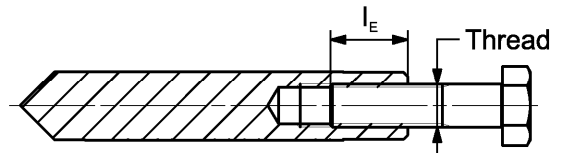
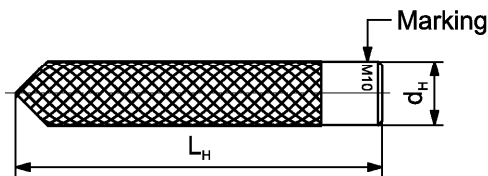

**Marking:** Anchor size e. g.: **M10**  
 Stainless steel → additional R; e.g.: **M10 R**  
 High corrosion resistant steel R → additional C; e.g.: **M10 HCR**

Retaining bolt or threaded rods (including nut and washer) must comply with the appropriate material and strength class of Annex A 7, Table A7.1

**Installation conditions:**

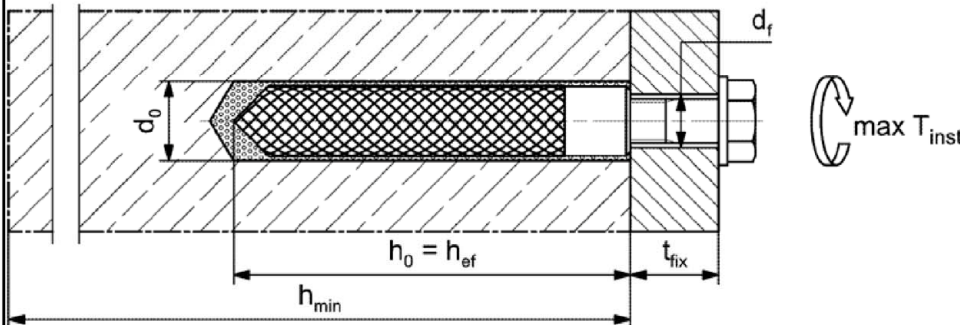

Figures not to scale

fischer Superbond

**Intended use**  
 Installation parameters for fischer internal threaded anchors RG MI

**Annex B 6**

Appendix 15/ 40

**Table B7.1: Installation parameters for reinforcing bars**

Nominal diameter of the bar		$\phi$	8 <sup>1)</sup>	10 <sup>1)</sup>	12 <sup>1)</sup>	14	16	20	25	28	32			
Nominal drill hole diameter	$d_0$	[mm]	10	12	12	14	14	16	18	20	25	30	35	40
Drill hole depth	$h_0$		$h_0 = h_{ef}$											
Effective embedment depth	$h_{ef,min}$		60	60	70	75	80	90	100	112	128			
	$h_{ef,max}$		160	200	240	280	320	400	500	560	640			
Minimum spacing and minimum edge distance	$s_{min}$ = $c_{min}$		40	45	55	60	65	85	110	130	160			
Minimum thickness of concrete member	$h_{min}$	$h_{ef} + 30$ ( $\geq 100$ )			$h_{ef} + 2d_0$									

<sup>1)</sup> Both drill hole diameters can be used

**Reinforcing bar**



- The minimum value of related rib area  $f_{R,min}$  must fulfil the requirements of EN 1992-1-1:2004+AC:2010
- The rib height must be within the range:  $0,05 \cdot \phi \leq h_{rib} \leq 0,07 \cdot \phi$   
( $\phi$  = Nominal diameter of the bar,  $h_{rib}$  = rib height)

**Installation conditions:**

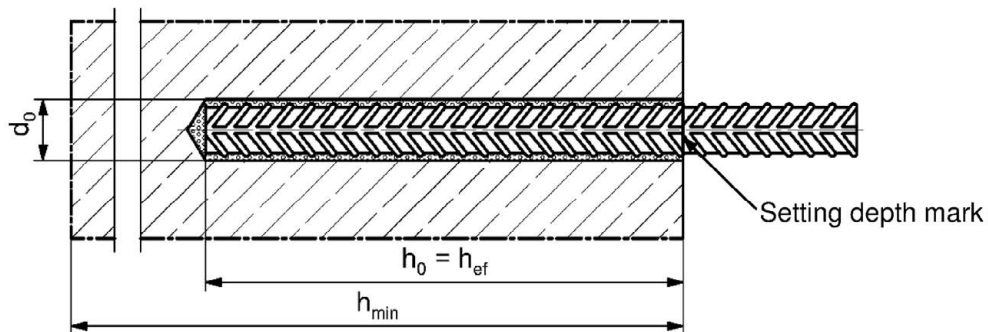

Figures not to scale

fischer Superbond

**Intended use**  
Installation parameters reinforcing bars

**Annex B 7**

Appendix 16/ 40

**Table B8.1:** Installation parameters for **fischer rebar anchor FRA**

Rebar anchor FRA		Thread	M12 <sup>1)</sup>	M16	M20	M24
Nominal diameter of the bar	$\phi$	[mm]	12	16	20	25
Width across flats	SW		19	24	30	36
Nominal drill hole diameter	$d_0$		14	16	20	30
Drill hole depth	$h_0$		$h_{ef} + l_e$			
Effective embedment depth	$h_{ef,min}$		70	80	90	96
	$h_{ef,max}$		140	220	300	380
Distance concrete surface to welded joint	$l_e$		100			
Minimum spacing and minimum edge distance	$s_{min}$		55	65	85	105
	$c_{min}$					
Diameter of clearance hole in the fixture	pre-positioned anchorage $\leq d_f$		14	18	22	26
	push through anchorage $\leq d_f$	18	22	26	32	
Minimum thickness of concrete member	$h_{min}$	$h_0 + 30$	$h_0 + 2d_0$			
Maximum installation torque	$\max T_{inst}$	[Nm]	40	60	120	150

<sup>1)</sup> Both drill hole diameters can be used

**fischer rebar anchor FRA**

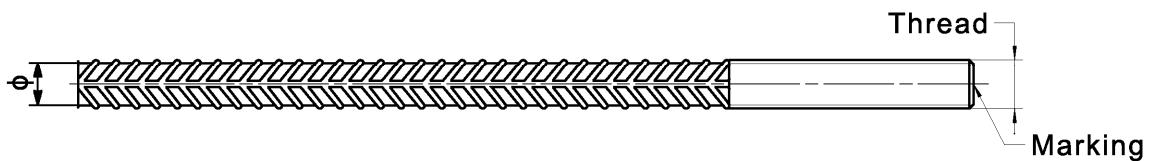

Marking frontal e. g:

- FRA (for stainless steel);
- FRA HCR (for high corrosion resistant steel)

**Installation conditions:**

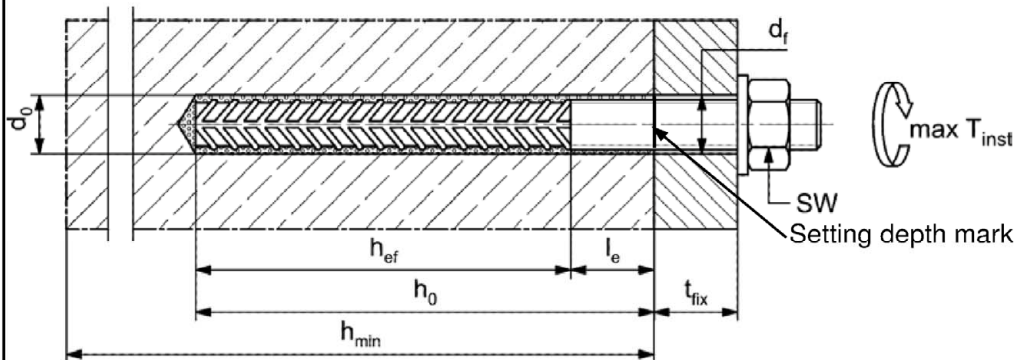

Figures not to scale

fischer Superbond

**Intended use**  
Installation parameters rebar anchor FRA

**Annex B 8**

Appendix 17/ 40

**Table B9.1: Dimension of resin capsule RSB**

Resin capsule RSB		RSB 8	RSB 10 mini	RSB 10	RSB 12 mini	RSB 12	RSB 16 mini	RSB 16	RSB 16 E	RSB 20	RSB 20 E / 24	RSB 30
Capsule diameter	$d_p$	9,0	10,5		12,5		16,5			23,0		27,5
Capsule length	$L_p$	85	72	90	72	97	72	95	123	160	190	260

**Table B9.2: Assignment of resin capsule RSB to fischer anchor rod RG M**

Anchor rod RG M		M8	M10	M12	M16	M20	M24	M30
Effective embedment depth	$h_{ef,1}$ [mm]	---	75	75	95	---	---	---
Related capsule RSB	[-]	---	10 mini	12 mini	16 mini	---	---	---
Effective embedment depth	$h_{ef,2}$ [mm]	80	90	110	125	170	210	280
Related capsule RSB	[-]	8	10	12	16	20	20 E / 24	30
Effective embedment depth	$h_{ef,3}$ [mm]	---	150	150	190	210	---	---
Related capsule RSB	[-]	---	2 x 10 mini	2 x 12 mini	2 x 16 mini	20 E / 24	---	---

**Table B9.3: Assignment of resin capsule RSB to fischer internal threaded anchor RG MI**

Internal threaded anchor RG MI		M8	M10	M12	M16	M20
Effective embedment depth	$h_{ef}$ [mm]	90	90	125	160	200
Related capsule RSB	[-]	10	12	16	16 E	20 E / 24

Figures not to scale

fischer Superbond

**Intended use**

Dimensions of the capsules; Assignment of the capsule to the fischer anchor rod RG M and fischer internal threaded anchor RG MI

**Annex B 9**

Appendix 18/ 40

**Table B10.1:** Parameters of the cleaning brush BS / BSB (steel brush with steel bristles)

The size of the cleaning brush refers to the drill hole diameter

Nominal drill hole diameter	$d_0$		10	12	14	16	18	20	24	25	28	30	32	35	40
Steel brush diameter BS	$d_b$	[mm]	11	14	16	20		25	26	27	30	40			-
Steel brush diameter BSB	$d_b$		-	-	-	-		-	-	-	-	-			42



**Table B10.2:** Maximum **processing time** of the mortar and minimum **curing time** (During the curing time of the mortar the concrete temperature may not fall below the listed minimum temperature. Minimal cartridge temperature +5 °C; minimal resin capsule temperature -15 °C)

Temperature at anchoring base [°C]	Maximum processing time $t_{work}$		Minimum curing time $t_{cure}$		
	FIS SB	FIS SB High Speed	FIS SB	FIS SB High Speed	RSB
-30 to -20	---	---	---	---	120 h
> -20 to -15	---	60 min	---	24 h	48 h
> -15 to -10	60 min	30 min	36 h	8 h	30 h
> -10 to -5	30 min	15 min	24 h	3 h	16 h
> -5 to 0	20 min	10 min	8 h	2 h	10 h
> 0 to 5	13 min	5 min	4 h	1 h	45 min
> 5 to 10	9 min	3 min	2 h	45 min	30 min
> 10 to 20	5 min	2 min	1 h	30 min	20 min
> 20 to 30	4 min	1 min	45 min	15 min	5 min
> 30 to 40	2 min	---	30 min	---	3 min

Figures not to scale

fischer Superbond







**Intended use**  
Cleaning brush (steel brush)  
Processing time and curing time

**Annex B 10**

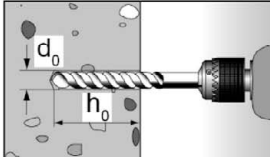
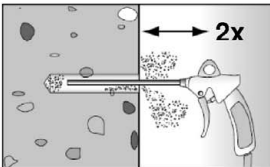
Appendix 19/ 40

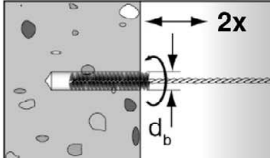
## Installation instructions part 1; Injection mortar system FIS SB

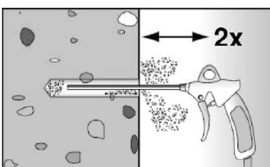
### Drilling and cleaning the hole (hammer drilling with standard drill bit)

1		<p>Drill the hole. Nominal drill hole diameter <math>d_0</math> and drill hole depth <math>h_0</math> see <b>tables B4.1, B6.1, B7.1, B8.1</b></p>	
2		<p>Clean the drill hole: Blow out the drill hole twice, with oil free compressed air (<math>p \geq 6</math> bar) In uncracked concrete the use of the manual blow-out pump ABG is possible (Installation parameters: <math>d_0 &lt; 18</math> mm and <math>h_{ef} &lt; 10d</math>)</p>	
3		<p>Brush the drill hole twice. For drill hole diameter <math>\geq 30</math> mm use a power drill. For deep holes use an extension. Corresponding brushes see <b>table B10.1</b></p>	
4		<p>Clean the drill hole: Blow out the drill hole twice, with oil free compressed air (<math>p \geq 6</math> bar) In uncracked concrete the use of the manual blow-out pump ABG is possible (Installation parameters: <math>d_0 &lt; 18</math> mm and <math>h_{ef} &lt; 10d</math>)</p>	

Go to step 5 (Annex B 12)

### Drilling and cleaning the hole (hammer drilling with hollow drill bit)

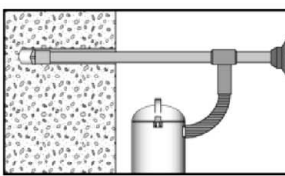
1		<p>Check a suitable hollow drill (see <b>table B1.1</b>) for correct operation of the dust extraction</p>
2		<p>Use a suitable dust extraction system, e. g. fischer FVC 35 M or a comparable dust extraction system with equivalent performance data.  Drill the hole with hollow drill bit. The dust extraction system has to extract the drill dust nonstop during the drilling process and must be adjusted to maximum power. Nominal drill hole diameter <math>d_0</math> and drill hole depth <math>h_0</math> see <b>tables B4.1, B6.1, B7.1, B8.1</b></p>

Go to step 5 (Annex B 12)

fischer Superbond





**Intended use**  
Installation instructions part 1; injection mortar system FIS SB

**Annex B 11**

Appendix 20/ 40

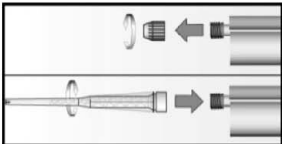
# Installation instructions part 2; injection mortar system FIS SB

## Preparing the cartridge

5		<p>Remove the sealing cap Screw on the static mixer (the spiral in the static mixer must be clearly visible)</p>
6		 <p>Place the cartridge into the dispenser</p>
7		 <p>Extrude approximately 10 cm of material out until the resin is evenly grey in colour. Do not use mortar that is not uniformly grey</p>

## Injection of the mortar

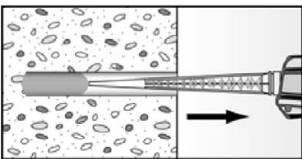
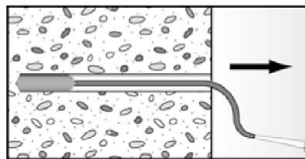
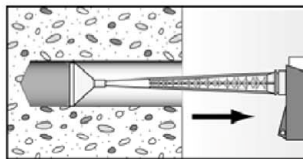
8	 <p>Fill approximately 2/3 of the drill hole with mortar. Always begin from the bottom of the hole and avoid bubbles</p>	 <p>For drill hole depth <math>\geq 150</math> mm use an extension tube</p>	 <p>For overhead installation, deep holes (<math>h_0 &gt; 250</math> mm) or drill hole diameter (<math>d_0 \geq 40</math> mm) use an injection-adapater</p>
---	---	--	--

Go to step 9 (Annex B 13)

fischer Superbond

**Intended use**  
Installation instructions part 2; injection mortar system FIS SB



**Annex B 12**

Appendix 21/ 40



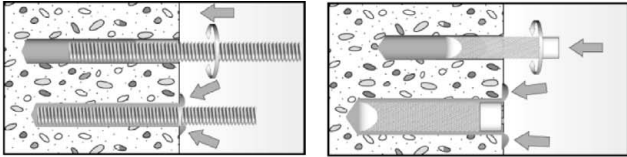
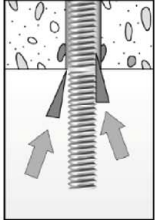
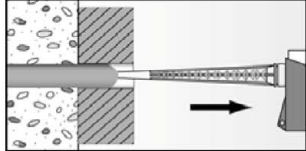

# Installation instructions part 3; injection mortar system FIS SB

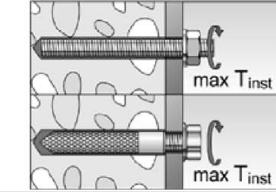
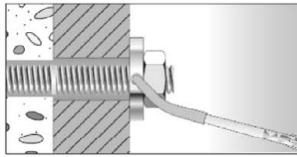
## Installation of anchor rods or fischer internal threaded anchors RG MI

9		<p>Only use clean and oil-free metal part. Mark the setting depth of the metal part. Push the anchor rod or fischer internal threaded RG MI anchor down to the bottom of the hole, turning it slightly while doing so. After inserting the metal part, excess mortar must be emerged around the anchor element. If not, pull out the metal part immediately and reinject mortar.</p>
	 <p>For overhead installations support the metal part with wedges. (e. g. fischer centering wedges)</p>	 <p>For push through installation fill the annular gap with mortar</p>
11	 <p>Wait for the specified curing time <math>t_{cure}</math> see <b>table B10.2</b></p>	<p>12</p>  <p>Mounting the fixture <math>max T_{inst}</math> see <b>tables B4.1 and B6.1</b></p>
Option		<p>After the minimum curing time is reached, the gap between metal part and fixture (annular clearance) may be filled with mortar via the fischer filling disc. Compressive strength <math>\geq 50 \text{ N/mm}^2</math> (e.g. fischer injection mortars FIS HB, FIS SB, FIS V, FIS EM Plus)  <b>ATTENTION:</b> Using fischer filling disc reduces <math>t_{fix}</math> (usable length of the anchor)</p>

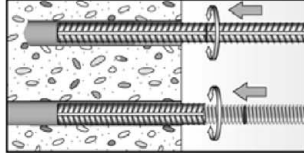
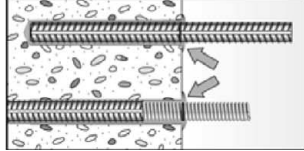
## Installation reinforcing bars and fischer rebar anchor FRA

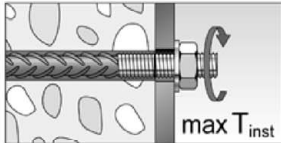

10		<p>Only use clean and oil-free reinforcing bars or fischer FRA. Mark the setting depth. Turn while using force to push the reinforcement bar or the fischer FRA into the filled hole up to the setting depth mark</p>
		<p>When the setting depth mark is reached, excess mortar must be emerged from the mouth of the drill hole. If not, pull out the anchor element immediately and reinject mortar.</p>
11	 <p>Wait for the specified curing time <math>t_{cure}</math> see <b>table B10.2</b></p>	<p>12</p>  <p>Mounting the fixture <math>max T_{inst}</math> see <b>table B8.1</b></p>

fischer Superbond	
<p><b>Intended use</b>          Installation instructions part 3; injection mortar system FIS SB</p>	<p><b>Annex B 13</b>          Appendix 22/ 40</p>

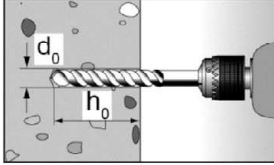
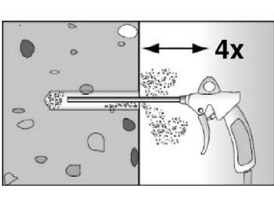

## Installation instructions part 4; resin capsule RSB

### Drilling and cleaning the hole (hammer drilling with standard drill bit)

1		<p>Drill the hole. Nominal drill hole diameter <math>d_0</math> and drill hole depth <math>h_0</math> see <b>tables B5.1</b> and <b>B6.1</b></p>	
2		<p>Clean the drill hole: Blow out the drill hole four times, with oil free compressed air (<math>p \geq 6</math> bar) In uncracked concrete the use of the manual blow-out pump ABG is possible (Installation parameters: <math>d_0 &lt; 18</math> mm and <math>h_{ef} &lt; 10d</math>)</p>	

Go to step 6 (Annex B 15)

### Drilling and cleaning the hole (wet drilling with diamond drill bit)

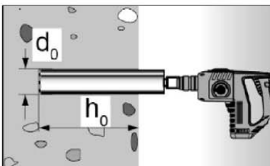
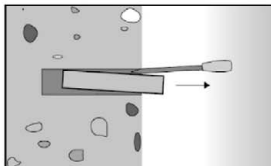
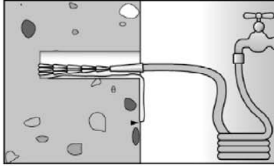
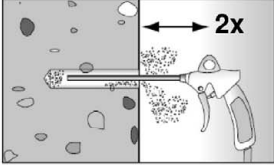
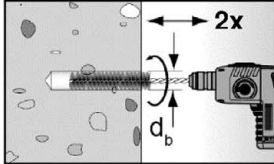
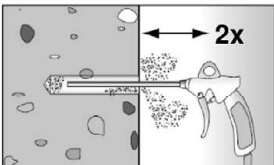
1		<p>Drill the hole. Drill hole diameter <math>d_0</math> and drill hole depth <math>h_0</math> see <b>tables B5.1</b> and <b>B6.1</b></p>		<p>Break the drill core and remove it</p>
2		<p>Flush the drill hole with clean water until it flows clear</p>		
3		<p>Blow out the drill hole twice, using oil-free compressed air (<math>p &gt; 6</math> bar)</p>		
4		<p>Brush the drill hole twice using a power drill. Corresponding brushes see <b>table B10.1</b></p>		
5		<p>Blow out the drill hole twice, using oil-free compressed air (<math>p &gt; 6</math> bar)</p>		

Go to step 6 (Annex B 15)

fischer Superbond

**Intended use**  
Installation instructions part 4; resin capsule RSB

**Annex B 14**

Appendix 23/ 40

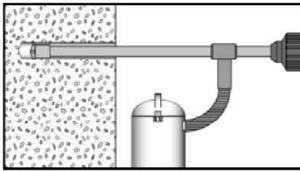

## Installation instructions part 5; resin capsule RSB

### Drilling and cleaning the hole (hammer drilling with hollow drill bit)

1		<p>Check a suitable hollow drill (see <b>table B2.1</b>) for correct operation of the dust extraction</p>
2		<p>Use a suitable dust extraction system, e. g. fischer FVC 35 M or a comparable dust extraction system with equivalent performance data.</p> <p>Drill the hole with hollow drill bit. The dust extraction system has to extract the drill dust nonstop during the drilling process and must be adjusted to maximum power. Nominal drill hole diameter <math>d_0</math> and drill hole depth <math>h_0</math> see <b>tables B5.1</b> and <b>B6.1</b></p>

Go to step 6 (Annex B 15)

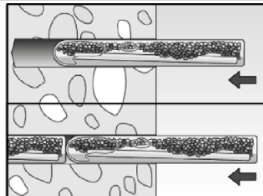
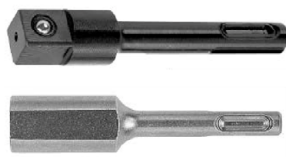
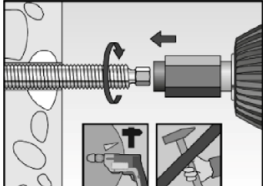
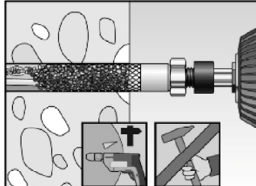
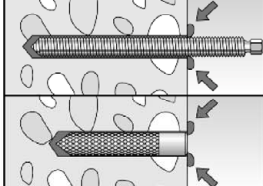
### Installation fischer anchor rod RG M or fischer internal threaded anchor RG MI

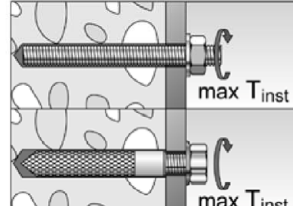
6		<p>Insert the resin capsule into the drill hole by hand. Suitable resin capsule RSB or RSB mini see <b>table B9.2</b>.</p>	 <p>Depending on the metal part being installed, use a suitable setting tool</p>
7			<p>Only use clean and grease-free metal parts. Using a suitable adapter, drive the fischer anchor rod RG M or the fischer internal threaded anchor RG MI into the capsule using a hammer drill set on rotary hammer action. Stop when the metal parts reaches the bottom of the hole and is set to the correct embedment depth</p>
8		<p>When reaching the correct embedment depth, excess mortar must emerge from the mouth of the drill hole. If not, the metal parts must be pulled out directly and a second resin capsule must be pushed into the drill hole. Setting process must be repeated (Step 7)</p>	
9	 <p>Wait for the specified curing time, <math>t_{cure}</math> see <b>table B10.2</b></p>	<p>10</p>  <p>Mounting the fixture <math>max T_{inst}</math> see <b>tables B5.1</b> and <b>B6.1</b></p>	

fischer Superbond

**Intended use**  
Installation instructions part 5; resin capsule RSB

**Annex B 15**

Appendix 24/ 40

**Table C1.1:** Characteristic values for **steel failure** under tension / shear load of **fischer anchor rods** and **standard threaded rods**

Anchor rod / standard threaded rod		M8	M10	M12	M16	M20	M24	M27	M30			
<b>Bearing capacity under tension load, steel failure <sup>3)</sup></b>												
Characteristic resistance $N_{Rk,s}$	Steel zinc plated	Property class	4.8	[kN]	15(13)	23(21)	33	63	98	141	184	224
			5.8		19(17)	29(27)	43	79	123	177	230	281
			8.8		29(27)	47(43)	68	126	196	282	368	449
	Stainless steel R and high corrosion resistant steel HCR	Property class	50	19	29	43	79	123	177	230	281	
			70	26	41	59	110	172	247	322	393	
			80	30	47	68	126	196	282	368	449	
<b>Partial factors <sup>1)</sup></b>												
Partial factor $\gamma_{Ms,N}$	Steel zinc plated	Property class	4.8	[-]	1,50							
			5.8		1,50							
			8.8		1,50							
	Stainless steel R and high corrosion resistant steel HCR	50	2,86									
		70	1,50 <sup>2)</sup> / 1,87									
		80	1,60									
<b>Bearing capacity under shear load, steel failure <sup>3)</sup></b>												
<b>without lever arm</b>												
Characteristic resistance $V_{Rk,s}$	Steel zinc plated	Property class	4.8	[kN]	9(8)	14(13)	20	38	59	85	110	135
			5.8		11(10)	17(16)	25	47	74	106	138	168
			8.8		15(13)	23(21)	34	63	98	141	184	225
	Stainless steel R and high corrosion resistant steel HCR	Property class	50		9	15	21	39	61	89	115	141
			70		13	20	30	55	86	124	161	197
			80		15	23	34	63	98	141	184	225
Ductility factor	$k_7$	[-]	1,0									
<b>with lever arm</b>												
Characteristic resistance $M_{Rk,s}$	Steel zinc plated	Property class	4.8	[Nm]	15(13)	30(27)	52	133	259	448	665	899
			5.8		19(16)	37(33)	65	166	324	560	833	1123
			8.8		30(26)	60(53)	105	266	519	896	1333	1797
	Stainless steel R and high corrosion resistant steel HCR	Property class	50		19	37	65	166	324	560	833	1123
			70		26	52	92	232	454	784	1167	1573
			80		30	60	105	266	519	896	1333	1797
<b>Partial factors <sup>1)</sup></b>												
Partial factor $\gamma_{Ms,V}$	Steel zinc plated	Property class	4.8	[-]	1.25							
			5.8		1.25							
			8.8		1.25							
	Stainless steel R and high corrosion resistant steel HCR	50	2.38									
		70	1.25 <sup>2)</sup> / 1.56									
		80	1.33									

<sup>1)</sup> In absence of other national regulations

<sup>2)</sup> Only admissible for high corrosion resistant steel C, with  $f_{yk} / f_{uk} \geq 0,8$  and  $A_s > 12 \%$  (e.g. fischer anchor rods)

<sup>3)</sup> Values in brackets are valid for undersized threaded rods with smaller stress area  $A_s$  for hotdip galvanized standard threaded rods according to EN ISO 10684:2004+AC:2009

fischer Superbond

**Performances**

Characteristic values for steel failure capacity of fischer anchor rods and standard threaded rods

**Annex C 1**

Appendix 25/ 40

**Table C2.1: Characteristic values for steel failure under tension / shear load of fischer internal threaded anchors RG MI**

fischer internal threaded anchors RG MI				M8	M10	M12	M16	M20	
<b>Bearing capacity under tension load, steel failure</b>									
Charact. resistance with screw	$N_{Rk,s}$	Property class	5.8	[kN]	19	29	43	79	123
			8.8		29	47	68	108	179
		Property class 70	R		26	41	59	110	172
			HCR		26	41	59	110	172
<b>Partial factors<sup>1)</sup></b>									
Partial factors	$\gamma_{Ms,N}$	Property class	5.8	[-]	1,50				
			8.8		1,50				
		Property class 70	R		1,87				
			HCR		1,87				
<b>Bearing capacity under shear load, steel failure</b>									
<b>Without lever arm</b>									
Charact. resistance with screw	$V^0_{Rk,s}$	Property class	5.8	[kN]	9,2	14,5	21,1	39,2	62,0
			8.8		14,6	23,2	33,7	54,0	90,0
		Property class 70	R		12,8	20,3	29,5	54,8	86,0
			HCR		12,8	20,3	29,5	54,8	86,0
Ductility factor		$k_7$	[-]	1,0					
<b>With lever arm</b>									
Charact. resistance with screw	$M^0_{Rk,s}$	Property class	5.8	[Nm]	20	39	68	173	337
			8.8		30	60	105	266	519
		Property class 70	R		26	52	92	232	454
			HCR		26	52	92	232	454
<b>Partial factors<sup>1)</sup></b>									
Partial factors	$\gamma_{Ms,V}$	Property class	5.8	[-]	1,25				
			8.8		1,25				
		Property class 70	R		1,56				
			HCR		1,56				

<sup>1)</sup> In absence of other national regulations

fischer Superbond

**Performances**

Characteristic values for steel failure under tension / shear load  
fischer internal threaded anchor RG MI

**Annex C 2**

Appendix 26/ 40

**Table C3.1:** Characteristic values for **steel failure** under tension / shear load of reinforcing bars

Nominal diameter of the bar	$\phi$	8	10	12	14	16	20	25	28	32
<b>Bearing capacity under tension load, steel failure</b>										
Characteristic resistance	$N_{Rk,s}$	[kN]	$A_s \cdot f_{uk}^{1)}$							
<b>Bearing capacity under shear load, steel failure</b>										
<b>Without lever arm</b>										
Characteristic resistance	$V_{Rk,s}$	[kN]	$0,5 \cdot A_s \cdot f_{uk}^{1)}$							
Ductility factor	$k_7$	[-]	1,0							
<b>With lever arm</b>										
Characteristic resistance	$M^0_{Rk,s}$	[Nm]	$1,2 \cdot W_{el} \cdot f_{uk}^{1)}$							

<sup>1)</sup>  $f_{uk}$  or  $f_{yk}$  respectively must be taken from the specifications of the reinforcing bar

**Table C3.2:** Characteristic values for **steel failure** under tension / shear load of **fischer rebar anchors FRA**

fischer rebar anchor FRA		M12	M16	M20	M24	
<b>Bearing capacity under tension load, steel failure</b>						
Characteristic resistance	$N_{Rk,s}$	[kN]	63	111	173	270
<b>Partial factor<sup>1)</sup></b>						
Partial factor	$\gamma_{Ms,N}$	[-]	1,4			
<b>Bearing capacity under shear load, steel failure</b>						
<b>Without lever arm</b>						
Characteristic resistance	$V_{Rk,s}$	[kN]	30	55	86	124
Ductility factor	$k_7$	[-]	1,0			
<b>With lever arm</b>						
Characteristic resistance	$M^0_{Rk,s}$	[Nm]	92	233	454	785
<b>Partial factor<sup>1)</sup></b>						
Partial factor	$\gamma_{Ms,V}$	[-]	1,56			

<sup>1)</sup> In absence of other national regulations

fischer Superbond

**Performances**

Characteristic values for steel failure under tension / shear load of reinforcing bars and fischer rebar anchors FRA

**Annex C 3**

Appendix 27/ 40

**Table C4.1:** Characteristic values for **concrete failure** under tension / shear load

Size		All sizes									
<b>Tension load</b>											
Installation factor	$\gamma_{inst}$	[-]	See annex C 5 to C 10 and C 15 to C 16								
<b>Factors for the compressive strength of concrete &gt; C20/25</b>											
Increasing factor for $\tau_{RK}$	C25/30	$\Psi_c$	[-]	1,02							
	C30/37			1,04							
	C35/45			1,07							
	C40/50			1,08							
	C45/55			1,09							
	C50/60			1,10							
<b>Splitting failure</b>											
Edge distance	$h / h_{ef} \geq 2,0$	$C_{cr,sp}$	[mm]	1,0 $h_{ef}$							
	$2,0 > h / h_{ef} > 1,3$			4,6 $h_{ef}$ - 1,8 h							
	$h / h_{ef} \leq 1,3$			2,26 $h_{ef}$							
Spacing	$S_{cr,sp}$			2 $C_{cr,sp}$							
<b>Concrete cone failure</b>											
Uncracked concrete	$k_{ucr,N}$	[-]	11,0								
Cracked concrete	$k_{cr,N}$		7,7								
Edge distance	$C_{cr,N}$	[mm]	1,5 $h_{ef}$								
Spacing	$S_{cr,N}$		2 $C_{cr,N}$								
<b>Factors for sustained tension load</b>											
Temperature range		[-]	24 °C / 40 °C	50 °C / 80 °C	72 °C / 120 °C	90 °C / 150 °C					
Factor	$\Psi_{sus}^0$	[-]	0,84	0,86	0,84	0,91					
<b>Shear load</b>											
Installation factor	$\gamma_{inst}$	[-]	1,0								
<b>Concrete pry-out failure</b>											
Factor for pry-out failure	$k_{\delta}$	[-]	2,0								
<b>Concrete edge failure</b>											
Effective length of fastener in shear loading	$l_f$	[mm]	for $d_{nom} \leq 24$ mm: min ( $h_{ef}$ ; 12 $d_{nom}$ ) for $d_{nom} > 24$ mm: min ( $h_{ef}$ ; 8 $d_{nom}$ ; 300 mm)								
<b>Calculation diameters</b>											
Size			M8	M10	M12	M16	M20	M24	M27	M30	
fischer anchor rods and standard threaded rods	$d_{nom}$	[mm]	8	10	12	16	20	24	27	30	
fischer internal threaded anchors RG MI	$d_{nom}$		12	16	18	22	28	- <sup>1)</sup>	- <sup>1)</sup>	- <sup>1)</sup>	
fischer rebar anchor FRA	$d_{nom}$		- <sup>1)</sup>	- <sup>1)</sup>	12	16	20	25	- <sup>1)</sup>	- <sup>1)</sup>	
Size (nominal diameter of the bar)	$\phi$		8	10	12	14	16	20	25	28	32
Reinforcing bar	$d_{nom}$	[mm]	8	10	12	14	16	20	25	28	32

<sup>1)</sup> Anchor type not part of the ETA

fischer Superbond

**Performances**

Characteristic values for concrete failure under tension / shear load

**Annex C 4**

Appendix 28/ 40

**Table C5.1:** Characteristic values for combined pull-out and concrete failure for **fischer anchor rods** and **standard threaded rods** in hammer drilled holes in combination with **injection mortar FIS SB; uncracked or cracked concrete**

Anchor rod / standard threaded rod		M8	M10	M12	M16	M20	M24	M27	M30	
<b>Combined pullout and concrete cone failure</b>										
Thread diameter	d	[mm]	8	10	12	16	20	24	27	30
<b>Uncracked concrete</b>										
<b>Characteristic bond resistance in uncracked concrete C20/25</b>										
Hammer-drilling with standard drill bit or hollow drill bit (dry or wet concrete)										
Temperature range	I: 24 °C / 40 °C	$\tau_{Rk,ucr}$ [N/mm <sup>2</sup> ]	12	13	13	13	13	12	10	10
	II: 50 °C / 80 °C		12	12	12	13	13	12	10	10
	III: 72 °C / 120 °C		10	11	11	11	11	11	9,0	9,0
	IV: 90 °C / 150 °C		10	10	10	11	10	10	8,0	8,0
<b>Installation factors</b>										
Dry or wet concrete	$\gamma_{inst}$	[-]	1,0							
<b>Cracked concrete</b>										
<b>Characteristic bond resistance in cracked concrete C20/25</b>										
Hammer-drilling with standard drill bit or hollow drill bit (dry or wet concrete)										
Temperature range	I: 24 °C / 40 °C	$\tau_{Rk,cr}$ [N/mm <sup>2</sup> ]	6,5	7,0	7,5	7,5	7,5	7,5	7,5	7,5
	II: 50 °C / 80 °C		6,0	6,5	7,5	7,5	7,5	7,5	7,0	7,0
	III: 72 °C / 120 °C		5,5	6,0	6,5	6,5	6,5	6,5	6,0	6,0
	IV: 90 °C / 150 °C		5,0	5,5	6,0	6,0	6,0	6,0	5,5	5,5
<b>Installation factors</b>										
Dry or wet concrete	$\gamma_{inst}$	[-]	1,0							

fischer Superbond

**Performances**

Characteristic values for combined pull-out and concrete failure for fischer anchor rod and standard threaded rods with injection mortar FIS SB

**Annex C 5**

Appendix 29/ 40

**Table C6.1:** Characteristic values for **combined pull-out** and concrete failure for **fischer anchor rods RG M** in hammer or diamond drilled holes in combination with **resin capsule RSB; uncracked or cracked concrete**

Anchor rod RG M			M8	M10	M12	M16	M20	M24	M30
<b>Combined pullout and concrete cone failure</b>									
Thread diameter	d	[mm]	8	10	12	16	20	24	30
<b>Uncracked concrete</b>									
<b>Characteristic bond resistance in uncracked concrete C20/25</b>									
Hammer-drilling with standard drill bit or hollow drill bit (dry or wet concrete as well as water filled hole)									
Temperature range	I: 24 °C / 40 °C	$\tau_{Rk,ucr}$ [N/mm <sup>2</sup> ]	12	13	13	13	13	12	10
	II: 50 °C / 80 °C		12	12	12	13	13	12	10
	III: 72 °C / 120 °C		10	11	11	11	11	11	9,0
	IV: 90 °C / 150 °C		10	10	10	11	10	10	8,0
Diamond-drilling (dry or wet concrete as well as water filled hole)									
Temperature range	I: 24 °C / 40 °C	$\tau_{Rk,ucr}$ [N/mm <sup>2</sup> ]	13	13	14	14	14	13	11
	II: 50 °C / 80 °C		12	13	13	14	13	13	10
	III: 72 °C / 120 °C		11	12	12	12	12	11	9,5
	IV: 90 °C / 150 °C		10	11	11	11	11	10	8,5
<b>Installation factors</b>									
Dry or wet concrete	$\gamma_{inst}$	[-]	1,0						
Water filled hole			1,2	1,0					
<b>Cracked concrete</b>									
<b>Characteristic bond resistance in cracked concrete C20/25</b>									
Hammer-drilling with standard drill bit or hollow drill bit (dry or wet concrete as well as water filled hole)									
Temperature range	I: 24 °C / 40 °C	$\tau_{Rk,cr}$ [N/mm <sup>2</sup> ]	6,5	7,0	7,5	7,5	7,5	7,5	7,5
	II: 50 °C / 80 °C		6,0	6,5	7,5	7,5	7,5	7,5	7,0
	III: 72 °C / 120 °C		5,5	6,0	6,5	6,5	6,5	6,5	6,0
	IV: 90 °C / 150 °C		5,0	5,5	6,0	6,0	6,0	6,0	5,5
Diamond-drilling (dry or wet concrete as well as water filled hole)									
Temperature range	I: 24 °C / 40 °C	$\tau_{Rk,cr}$ [N/mm <sup>2</sup> ]	- <sup>1)</sup>	- <sup>1)</sup>	- <sup>1)</sup>	7,5	7,5	7,5	7,5
	II: 50 °C / 80 °C		- <sup>1)</sup>	- <sup>1)</sup>	- <sup>1)</sup>	7,5	7,5	7,5	7,0
	III: 72 °C / 120 °C		- <sup>1)</sup>	- <sup>1)</sup>	- <sup>1)</sup>	6,5	6,5	6,5	6,5
	IV: 90 °C / 150 °C		- <sup>1)</sup>	- <sup>1)</sup>	- <sup>1)</sup>	6,0	6,0	6,0	6,0
<b>Installation factors</b>									
Dry or wet concrete	$\gamma_{inst}$	[-]	1,0						
Water filled hole			1,2	1,0					

<sup>1)</sup> No performance assessed

fischer Superbond

**Performances**

Characteristic values for combined pull-out and concrete failure for fischer anchor rod RG M with resin capsule RSB

**Annex C 6**

Appendix 30/ 40



**Table C7.1:** Characteristic values for **combined pull-out** and concrete failure for **fischer internal threaded anchors RG MI** in hammer drilled holes in combination with **injection mortar FIS SB; uncracked or cracked concrete**

Internal threaded anchor RG MI		M8	M10	M12	M16	M20
--------------------------------	--	----	-----	-----	-----	-----

**Combined pullout and concrete cone failure**

Sleeve diameter	d	[mm]	12	16	18	22	28
-----------------	---	------	----	----	----	----	----

**Uncracked concrete**

**Characteristic bond resistance in uncracked concrete C20/25**

Hammer-drilling with standard drill bit or hollow drill bit (dry or wet concrete)

Temperature range	I: 24 °C / 40 °C	$\tau_{Rk,ucr}$ [N/mm <sup>2</sup> ]	12	12	11	11	9,5
	II: 50 °C / 80 °C		12	11	11	10	9,0
	III: 72 °C / 120 °C		11	10	10	9,0	8,0
	IV: 90 °C / 150 °C		10	9,5	9,0	8,5	7,5

**Installation factors**

Dry or wet concrete	$\gamma_{inst}$	[-]	1,0			
---------------------	-----------------	-----	-----	--	--	--

**Cracked concrete**

**Characteristic bond resistance in cracked concrete C20/25**

Hammer-drilling with standard drill bit or hollow drill bit (dry or wet concrete)

Temperature range	I: 24 °C / 40 °C	$\tau_{Rk,cr}$ [N/mm <sup>2</sup> ]	5,0			
	II: 50 °C / 80 °C		5,0			
	III: 72 °C / 120 °C		4,5			
	IV: 90 °C / 150 °C		4,0			

**Installation factors**

Dry or wet concrete	$\gamma_{inst}$	[-]	1,0			
---------------------	-----------------	-----	-----	--	--	--

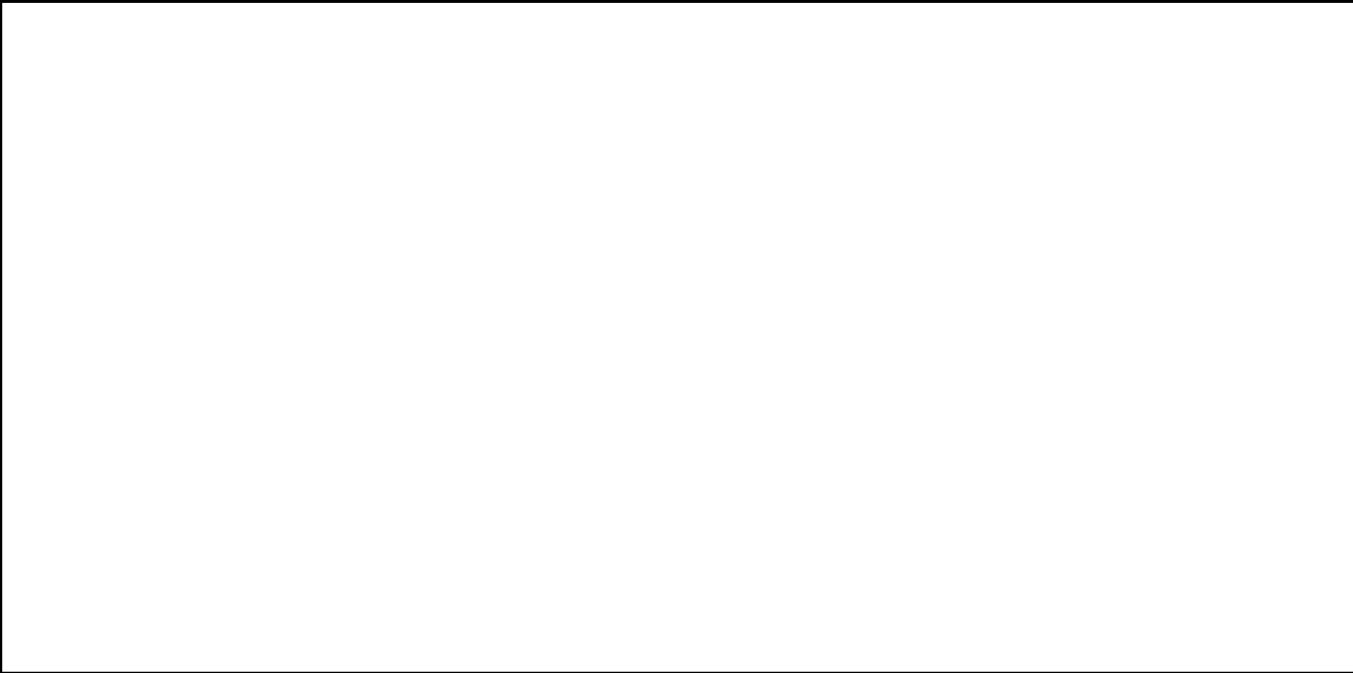

fischer Superbond

**Performances**

Characteristic values for combined pull-out and concrete failure for fischer internal threaded anchor RG MI with injection mortar FIS SB

**Annex C 7**

Appendix 31/ 40

**Table C8.1:** Characteristic values for **combined pull-out** and concrete failure for **fischer internal threaded anchors RG MI** in hammer or diamond drilled holes in combination with **resin capsule RSB; uncracked or cracked concrete**

Internal threaded anchor RG MI			M8	M10	M12	M16	M20
<b>Combined pullout and concrete cone failure</b>							
Sleeve diameter	d	[mm]	12	16	18	22	28
<b>Uncracked concrete</b>							
<b>Characteristic bond resistance in uncracked concrete C20/25</b>							
Hammer-drilling with standard drill bit or hollow drill bit (dry or wet concrete as well as water filled hole)							
Temperature range	I: 24 °C / 40 °C	$\tau_{Rk,ucr}$ [N/mm <sup>2</sup> ]	12	12	11	11	9,5
	II: 50 °C / 80 °C		12	11	11	10	9,0
	III: 72 °C / 120 °C		11	10	10	9,0	8,0
	IV: 90 °C / 150 °C		10	9,5	9,0	8,5	7,5
Diamond-drilling (dry or wet concrete as well as water filled hole)							
Temperature range	I: 24 °C / 40 °C	$\tau_{Rk,ucr}$ [N/mm <sup>2</sup> ]	13	12	12	11	10
	II: 50 °C / 80 °C		13	12	12	11	9,5
	III: 72 °C / 120 °C		11	11	10	9,5	8,5
	IV: 90 °C / 150 °C		10	10	9,5	9,0	8,0
<b>Installation factors</b>							
Dry or wet concrete	$\gamma_{inst}$	[-]	1,0				
Water filled hole			1,2	1,0			
<b>Cracked concrete</b>							
<b>Characteristic bond resistance in cracked concrete C20/25</b>							
Hammer-drilling with standard drill bit or hollow drill bit (dry or wet concrete as well as water filled hole)							
Temperature range	I: 24 °C / 40 °C	$\tau_{Rk,cr}$ [N/mm <sup>2</sup> ]	5,0				
	II: 50 °C / 80 °C		5,0				
	III: 72 °C / 120 °C		4,5				
	IV: 90 °C / 150 °C		4,0				
Diamond-drilling (dry or wet concrete as well as water filled hole)							
Temperature range	I: 24 °C / 40 °C	$\tau_{Rk,cr}$ [N/mm <sup>2</sup> ]	- <sup>1)</sup>	5,0			
	II: 50 °C / 80 °C		- <sup>1)</sup>	5,0			
	III: 72 °C / 120 °C		- <sup>1)</sup>	4,5			
	IV: 90 °C / 150 °C		- <sup>1)</sup>	4,0			
<b>Installation factors</b>							
Dry or wet concrete	$\gamma_{inst}$	[-]	1,0				
Water filled hole			1,2	1,0			
<sup>1)</sup> No performance assessed							

fischer Superbond

**Performances**

Characteristic values for combined pull-out and concrete failure for fischer internal threaded anchor RG MI with resin capsule RSB

**Annex C 8**

Appendix 32/ 40

**Table C9.1:** Characteristic values for **combined pull-out** and concrete failure for **reinforcing bars** in hammer drilled holes in combination with **injection mortar FIS SB; uncracked or cracked concrete**

Nominal diameter of the bar		$\phi$	8	10	12	14	16	20	25	28	32		
<b>Combined pullout and concrete cone failure</b>													
Bar diameter		d	[mm]	8	10	12	14	16	20	25	28	32	
<b>Uncracked concrete</b>													
<b>Characteristic bond resistance in uncracked concrete C20/25</b>													
<u>Hammer-drilling with standard drill bit or hollow drill bit (dry or wet concrete)</u>													
Tem- perature range	I: 24 °C / 40 °C		$\tau_{Rk,ucr}$	[N/mm <sup>2</sup> ]	8,0	8,5	9,0	9,5	9,5	10	9,5	9,0	7,5
	II: 50 °C / 80 °C				8,0	8,5	9,0	9,0	9,5	9,5	9,0	8,5	7,5
	III: 72 °C / 120 °C				7,0	7,5	8,0	8,0	8,5	8,5	8,0	7,5	6,5
	IV: 90 °C / 150 °C				6,5	7,0	7,0	7,5	7,5	8,0	7,5	7,0	6,0
<b>Installation factors</b>													
Dry or wet concrete		$\gamma_{inst}$	[-]	1,0									
<b>Cracked concrete</b>													
<b>Characteristic bond resistance in cracked concrete C20/25</b>													
<u>Hammer-drilling with standard drill bit or hollow drill bit (dry or wet concrete)</u>													
Tem- perature range	I: 24 °C / 40 °C		$\tau_{Rk,cr}$	[N/mm <sup>2</sup> ]	4,5	6,0	6,0	6,0	7,0	6,0	6,0	6,0	6,0
	II: 50 °C / 80 °C				4,5	5,5	5,5	5,5	6,5	6,0	6,0	6,0	6,0
	III: 72 °C / 120 °C				4,0	5,0	5,0	5,0	6,0	5,5	5,5	5,5	5,5
	IV: 90 °C / 150 °C				3,5	4,5	4,5	4,5	5,5	5,0	5,0	5,0	5,0
<b>Installation factors</b>													
Dry or wet concrete		$\gamma_{inst}$	[-]	1,0									

fischer Superbond

**Performances**

Characteristic values for combined pull-out and concrete failure for reinforcing bars with injection mortar FIS SB

**Annex C 9**

Appendix 33/ 40

**Table C10.1:** Characteristic values for **combined pull-out** and concrete failure for **fischer rebar anchors FRA** in hammer drilled holes in combination with **injection mortar FIS SB; uncracked or cracked concrete**

fischer rebar anchor FRA		M12	M16	M20	M24	
<b>Combined pullout and concrete cone failure</b>						
Bar diameter	d [mm]	12	16	20	25	
<b>Uncracked concrete</b>						
<b>Characteristic bond resistance in uncracked concrete C20/25</b>						
<u>Hammer-drilling with standard drill bit or hollow drill bit (dry or wet concrete)</u>						
Tem- perature range	I: 24 °C / 40 °C	$\tau_{Rk,ucr}$ [N/mm <sup>2</sup> ]	9,0	9,5	10	9,5
	II: 50 °C / 80 °C		9,0	9,5	9,5	9,0
	III: 72 °C / 120 °C		8,0	8,5	8,5	8,0
	IV: 90 °C / 150 °C		7,0	7,5	8,0	7,5
<b>Installation factors</b>						
Dry or wet concrete	$\gamma_{inst}$	[-]	1,0			
<b>Cracked concrete</b>						
<b>Characteristic bond resistance in cracked concrete C20/25</b>						
<u>Hammer-drilling with standard drill bit or hollow drill bit (dry or wet concrete)</u>						
Tem- perature range	I: 24 °C / 40 °C	$\tau_{Rk,cr}$ [N/mm <sup>2</sup> ]	6,0	7,0	6,0	6,0
	II: 50 °C / 80 °C		5,5	6,5	6,0	6,0
	III: 72 °C / 120 °C		5,0	6,0	5,5	5,5
	IV: 90 °C / 150 °C		4,5	5,5	5,0	5,0
<b>Installation factors</b>						
Dry or wet concrete	$\gamma_{inst}$	[-]	1,0			

fischer Superbond

**Performances**

Characteristic values for combined pull-out and concrete failure for fischer rebar anchors FRA with injection mortar FIS SB

**Annex C 10**

Appendix 34/ 40

**Table C11.1: Displacements for anchor rods**

Anchor rod		M8	M10	M12	M16	M20	M24	M27	M30
<b>Displacement-Factors for tension load<sup>1)</sup></b>									
<b>Uncracked or cracked concrete; Temperature range I, II, III, IV</b>									
$\delta_{N0}$ -Factor	[mm/(N/mm <sup>2</sup> )]	0,07	0,08	0,09	0,10	0,11	0,12	0,12	0,13
$\delta_{N\infty}$ -Factor		0,13	0,14	0,15	0,17	0,17	0,18	0,19	0,19
<b>Displacement-Factors for shear load<sup>2)</sup></b>									
<b>Uncracked or cracked concrete; Temperature range I, II, III, IV</b>									
$\delta_{V0}$ -Factor	[mm/kN]	0,18	0,15	0,12	0,09	0,07	0,06	0,05	0,05
$\delta_{V\infty}$ -Factor		0,27	0,22	0,18	0,14	0,11	0,09	0,08	0,07
1) Calculation of effective displacement: $\delta_{N0} = \delta_{N0}\text{-Factor} \cdot \tau_{Ed}$ $\delta_{N\infty} = \delta_{N\infty}\text{-Factor} \cdot \tau_{Ed}$ ( $\tau_{Ed}$ : Design value of the applied tensile stress)					2) Calculation of effective displacement: $\delta_{V0} = \delta_{V0}\text{-Factor} \cdot V_{Ed}$ $\delta_{V\infty} = \delta_{V\infty}\text{-Factor} \cdot V_{Ed}$ ( $V_{Ed}$ : Design value of the applied shear force)				

**Table C11.2: Displacements for fischer internal threaded anchors RG MI**

Internal threaded anchor RG MI		M8	M10	M12	M16	M20
<b>Displacement-Factors for tension load<sup>1)</sup></b>						
<b>Uncracked or cracked concrete; Temperature range I, II, III, IV</b>						
$\delta_{N0}$ -Factor	[mm/(N/mm <sup>2</sup> )]	0,09	0,10	0,10	0,11	0,19
$\delta_{N\infty}$ -Factor		0,13	0,15	0,15	0,17	0,19
<b>Displacement-Factors for shear load<sup>2)</sup></b>						
<b>Uncracked or cracked concrete; Temperature range I, II, III, IV</b>						
$\delta_{V0}$ -Factor	[mm/kN]	0,12	0,09	0,08	0,07	0,05
$\delta_{V\infty}$ -Factor		0,18	0,14	0,12	0,10	0,08
1) Calculation of effective displacement: $\delta_{N0} = \delta_{N0}\text{-Factor} \cdot \tau_{Ed}$ $\delta_{N\infty} = \delta_{N\infty}\text{-Factor} \cdot \tau_{Ed}$ ( $\tau_{Ed}$ : Design value of the applied tensile stress)				2) Calculation of effective displacement: $\delta_{V0} = \delta_{V0}\text{-Factor} \cdot V_{Ed}$ $\delta_{V\infty} = \delta_{V\infty}\text{-Factor} \cdot V_{Ed}$ ( $V_{Ed}$ : Design value of the applied shear force)		

fischer Superbond

**Performances**

Displacements for anchor rods and fischer internal threaded anchors RG MI

**Annex C 11**

Appendix 35/ 40

**Table C12.1: Displacements for reinforcing bars**

Nominal diameter of the bar $\phi$	8	10	12	14	16	20	25	28	32	
<b>Displacement-Factors for tension load<sup>1)</sup></b>										
<b>Uncracked or cracked concrete; Temperature range I, II, III, IV</b>										
$\delta_{N0}$ -Factor	[mm/(N/mm <sup>2</sup> )]	0,07	0,08	0,09	0,09	0,10	0,11	0,12	0,13	0,13
$\delta_{N\infty}$ -Factor		0,11	0,13	0,13	0,15	0,16	0,16	0,18	0,20	0,20
<b>Displacement-Factors for shear load<sup>2)</sup></b>										
<b>Uncracked or cracked concrete; Temperature range I, II, III, IV</b>										
$\delta_{V0}$ -Factor	[mm/kN]	0,18	0,15	0,12	0,10	0,09	0,07	0,06	0,05	0,05
$\delta_{V\infty}$ -Factor		0,27	0,22	0,18	0,16	0,14	0,11	0,09	0,08	0,06

1) Calculation of effective displacement:

$$\delta_{N0} = \delta_{N0}\text{-Factor} \cdot \tau_{Ed}$$

$$\delta_{N\infty} = \delta_{N\infty}\text{-Factor} \cdot \tau_{Ed}$$

( $\tau_{Ed}$ : Design value of the applied tensile stress)

2) Calculation of effective displacement:

$$\delta_{V0} = \delta_{V0}\text{-Factor} \cdot V_{Ed}$$

$$\delta_{V\infty} = \delta_{V\infty}\text{-Factor} \cdot V_{Ed}$$

( $V_{Ed}$ : Design value of the applied shear force)

**Table C12.2: Displacements for fischer rebar anchors FRA**

fischer rebar anchor FRA	M12	M16	M20	M24	
<b>Displacement-Factors for tension load<sup>1)</sup></b>					
<b>Uncracked or cracked concrete; Temperature range I, II, III, IV</b>					
$\delta_{N0}$ -Factor	[mm/(N/mm <sup>2</sup> )]	0,09	0,10	0,11	0,12
$\delta_{N\infty}$ -Factor		0,13	0,15	0,16	0,18
<b>Displacement-Factors for shear load<sup>2)</sup></b>					
<b>Uncracked or cracked concrete; Temperature range I, II, III, IV</b>					
$\delta_{V0}$ -Factor	[mm/kN]	0,12	0,09	0,07	0,06
$\delta_{V\infty}$ -Factor		0,18	0,14	0,11	0,09

1) Calculation of effective displacement:

$$\delta_{N0} = \delta_{N0}\text{-Factor} \cdot \tau_{Ed}$$

$$\delta_{N\infty} = \delta_{N\infty}\text{-Factor} \cdot \tau_{Ed}$$

( $\tau_{Ed}$ : Design value of the applied tensile stress)

2) Calculation of effective displacement:

$$\delta_{V0} = \delta_{V0}\text{-Factor} \cdot V_{Ed}$$

$$\delta_{V\infty} = \delta_{V\infty}\text{-Factor} \cdot V_{Ed}$$

( $V_{Ed}$ : Design value of the applied shear force)

fischer Superbond

**Performances**

Displacements for reinforcing bars and fischer rebar anchors FRA

**Annex C 12**

Appendix 36/ 40

**Table C13.1: Characteristic values for steel failure under tension / shear load of fischer anchor rods and standard threaded rods under seismic action performance category C1 or C2**

Anchor rod / standard threaded rod		M8	M10	M12	M16	M20	M24	M27	M30			
<b>Bearing capacity under tension load, steel failure<sup>1)</sup></b>												
<b>fischer anchor rods and standard threaded rods, performance category C1<sup>2)</sup></b>												
Characteristic resistance $N_{Rk,s,C1}$	Steel zinc plated	Property class	5.8	[kN]	19(17)	29(27)	43	79	123	177	230	281
			8.8		29(27)	47(43)	68	126	196	282	368	449
	Stainless steel R and high corrosion resistant steel HCR		50		19	29	43	79	123	177	230	281
			70		26	41	59	110	172	247	322	393
			80		30	47	68	126	196	282	368	449
<b>fischer anchor rods and standard threaded rods, performance category C2<sup>2)</sup></b>												
Characteristic resistance $N_{Rk,s,C2}$	Steel zinc plated	Property class	5.8	[-]	- <sup>4)</sup>	- <sup>4)</sup>	39	72	108	177	- <sup>4)</sup>	- <sup>4)</sup>
			8.8		- <sup>4)</sup>	- <sup>4)</sup>	61	116	173	282	- <sup>4)</sup>	- <sup>4)</sup>
	Stainless steel R and high corrosion resistant steel HCR		50		- <sup>4)</sup>	- <sup>4)</sup>	39	72	108	177	- <sup>4)</sup>	- <sup>4)</sup>
			70		- <sup>4)</sup>	- <sup>4)</sup>	53	101	152	247	- <sup>4)</sup>	- <sup>4)</sup>
			80		- <sup>4)</sup>	- <sup>4)</sup>	61	116	173	282	- <sup>4)</sup>	- <sup>4)</sup>
<b>Bearing capacity under shear load, steel failure without lever arm<sup>1)</sup></b>												
<b>fischer anchor rods, performance category C1<sup>2)</sup></b>												
Characteristic resistance $V_{Rk,s,C1}$	Steel zinc plated	Property class	5.8	[kN]	11(10)	17(16)	25	47	74	106	138	168
			8.8		15(13)	23(21)	34	63	98	141	184	225
	Stainless steel R and high corrosion resistant steel HCR		50		9	15	21	39	61	89	115	141
			70		13	20	30	55	86	124	161	197
			80		15	23	34	63	98	141	184	225
<b>Standard threaded rods, performance category C1<sup>2)</sup></b>												
Characteristic resistance $V_{Rk,s,C1}$	Steel zinc plated	Property class	5.8	[kN]	8(7)	12(11)	17	33	52	74	97	118
			8.8		11	16(14)	24	44	69	99	129	158
	Stainless steel R and high corrosion resistant steel HCR		50		6	11	15	27	43	62	81	99
			70		9	14	21	39	60	87	113	138
			80		11	16	24	44	69	99	129	158
<b>fischer anchor rods and standard threaded rods, performance category C2</b>												
Characteristic resistance $V_{Rk,s,C2}$	Steel zinc plated	Property class	5.8	[-]	- <sup>4)</sup>	- <sup>4)</sup>	14	27	43	62	- <sup>4)</sup>	- <sup>4)</sup>
			8.8		- <sup>4)</sup>	- <sup>4)</sup>	22	44	69	99	- <sup>4)</sup>	- <sup>4)</sup>
	Stainless steel R and high corrosion resistant steel HCR		50		- <sup>4)</sup>	- <sup>4)</sup>	14	27	43	62	- <sup>4)</sup>	- <sup>4)</sup>
			70		- <sup>4)</sup>	- <sup>4)</sup>	20	39	60	87	- <sup>4)</sup>	- <sup>4)</sup>
			80		- <sup>4)</sup>	- <sup>4)</sup>	22	44	69	99	- <sup>4)</sup>	- <sup>4)</sup>
Factor for the annular gap	$\alpha_{gap}$	[-]	0,5 (1,0) <sup>3)</sup>									

- 1) Partial factors for performance category C1 or C2 see table C14.2; for fischer anchor rods FIS A / RG M the factor for steel ductility is 1,0
- 2) Values in brackets are valid for undersized threaded rods with smaller stress area  $A_s$  for hot dip galvanised standard threaded rods according to EN ISO 10684:2004+AC:2009.
- 3) Values in brackets are valid for filled annular gaps between the anchor rod and the through-hole in the attachment. It is necessary to use the fischer filling disc according to Annex A 1 and A 3
- 4) No performance assessed

fischer Superbond

**Performances**

Characteristic values for steel failure under tension / shear load for fischer anchor rods and standard threaded rods under seismic action (performance category C1 / C2)

**Annex C 13**

Appendix 37/ 40

**Table C14.1:** Characteristic values for **steel failure** under tension / shear load for of **reinforcing bars (B500B)** under seismic action performance category **C1**

Nominal diameter of the bar	$\phi$	8	10	12	14	16	20	25	28	32	
<b>Bearing capacity under tension load, steel failure<sup>1)</sup></b>											
<b>Reinforcing bar B500B acc. to DIN 488-2:2009-08, performance category C1</b>											
Characteristic resistance	$N_{Rk,s,C1}$	[kN]	28	44	63	85	111	173	270	339	443
<b>Bearing capacity under shear load, steel failure without lever arm<sup>1)</sup></b>											
<b>Reinforcing bar B500B acc. to DIN 488-2:2009-08, performance category C1</b>											
Characteristic resistance	$V_{Rk,s,C1}$	[kN]	10	15	22	30	39	61	95	119	155

<sup>1)</sup> Partial factors for performance category C1 see table C14.2

**Table C14.2:** **Partial factors for fischer anchor rods, standard threaded rods and reinforcing bars (B500B)** under seismic action performance category **C1 or C2**

Anchor rod / standard threaded rod		M8	M10	M12	M16	M20	M24	M27	M30	
Nominal diameter of the bar	$\phi$	8	10	12	14	16	20	25	28	32

<b>Tension load, steel failure<sup>1)</sup></b>										
Partial factor $\gamma_{Ms,N}$	Steel zinc plated	Property class	5.8	[-]	1,50					
			8.8		1,50					
	Stainless steel R and high corrosion resistant steel HCR	50	2,86							
		70	1,50 <sup>2)</sup> / 1,87							
	Reinforcing bar	B500B	80		1,60					
					1,40					

<b>Shear load, steel failure<sup>1)</sup></b>										
Partial factor $\gamma_{Ms,V}$	Steel zinc plated	Property class	5.8	[-]	1,25					
			8.8		1,25					
	Stainless steel R and high corrosion resistant steel HCR	50	2,38							
		70	1,25 <sup>2)</sup> / 1,56							
	Reinforcing bar	B500B	80		1,33					
					1,50					

<sup>1)</sup> In absence of other national regulations

<sup>2)</sup> Only admissible for high corrosion resistant steel HCR, with  $f_{yk} / f_{uk} \geq 0,8$  and  $A_5 > 12\%$  (e.g. fischer anchor rods)

fischer Superbond

**Performances**

Characteristic values for steel failure under tension / shear load for reinforcing bars under seismic action (performance category C1); partial factors (performance category C1 / C2)

**Annex C 14**

Appendix 38/ 40



**Table C15.1:** Characteristic values for **combined pull-out** and concrete failure for **fischer anchor rods** and **standard threaded rods** in hammer drilled holes with **injection mortar FIS SB** or **resin capsule RSB** under seismic action performance category **C1**

Anchor rod / standard threaded rod		M8	M10	M12	M16	M20	M24	M27 <sup>1)</sup>	M30	
<b>Characteristic bond resistance, combined pullout and concrete cone failure</b>										
<b>Hammer-drilling with standard drill bit or hollow drill bit (dry or wet concrete; resin capsule RSB additional in water filled holes)</b>										
Temperature range	I: 24 °C / 40 °C	$\tau_{Rk,C1}$ [N/mm <sup>2</sup> ]	4,6	5,0	5,6	5,6	5,6	5,6	5,6	6,4
	II: 50 °C / 80 °C		4,3	4,6	5,6	5,6	5,6	5,6	5,3	6,0
	III: 72 °C / 120 °C		3,9	4,3	4,9	4,9	4,9	4,9	4,5	5,1
	IV: 90 °C / 150 °C		3,6	3,9	4,5	4,5	4,5	4,5	4,1	4,7
<b>Installation factors</b>										
Dry or wet concrete	$\gamma_{inst}$	[-]	1,0							
Water filled hole			1,2 <sup>2)</sup>	1,0 <sup>2)</sup>						

<sup>1)</sup> Only use with injection mortar FIS SB

<sup>2)</sup> Only use with resin capsule RSB in water filled hole

**Table C15.2:** Characteristic values for **combined pull-out** and concrete failure for **reinforcing bars** in hammer drilled holes with **injection mortar FIS SB** under seismic action performance category **C1**

Nominal diameter of the bar		$\phi$	8	10	12	14	16	20	25	28	32
<b>Characteristic bond resistance, combined pullout and concrete cone failure</b>											
<b>Hammer-drilling with standard drill bit or hollow drill bit (dry or wet concrete)</b>											
Temperature range	I: 24 °C / 40 °C	$\tau_{Rk,C1}$ [N/mm <sup>2</sup> ]	3,2	4,3	4,5	4,5	5,3	4,5	4,5	4,5	5,1
	II: 50 °C / 80 °C		3,2	3,9	4,1	4,1	4,9	4,5	4,5	4,5	5,1
	III: 72 °C / 120 °C		2,8	3,6	3,8	3,8	4,5	4,1	4,1	4,1	4,7
	IV: 90 °C / 150 °C		2,5	3,2	3,4	3,4	4,1	3,8	3,8	3,8	4,3
<b>Installation factors</b>											
Dry or wet concrete	$\gamma_{inst}$	[-]	1,0								

fischer Superbond

**Performances**

Characteristic values for combined pull-out and concrete failure under seismic action (performance category C1) for fischer anchor rods, standard threaded rods and reinf. bars

**Annex C 15**

Appendix 39/ 40

**Table C16.1:** Characteristic values for **combined pull-out** and concrete failure for **fischer anchor rods** and **standard threaded rods** in hammer drilled holes with **injection mortar FIS SB** under seismic action performance category **C2**

Anchor rod / standard threaded rod		M12	M16	M20	M24	
<b>Characteristic bond resistance, combined pullout and concrete cone failure</b>						
<b>Hammer-drilling with standard drill bit or hollow drill bit (dry or wet concrete)</b>						
Tem- per- a- ture range	I: 24 °C / 40 °C	$\tau_{Rk,C2}$ [N/mm <sup>2</sup> ]	4,5	3,2	2,6	3,0
	II: 50 °C / 80 °C		4,5	3,2	2,6	3,0
	III: 72 °C / 120 °C		3,9	2,7	2,3	2,6
	IV: 90 °C / 150 °C		3,6	2,5	2,1	2,4

**Installation factors**

Dry or wet concrete	$\gamma_{inst}$	[-]	1,0
---------------------	-----------------	-----	-----

**Displacement-Factors for tension load<sup>1)</sup>**

$\delta_{N,C2}$ (DLS)-Factor	[mm/(N/mm <sup>2</sup> )]	0,09	0,10	0,11	0,12
$\delta_{N,C2}$ (ULS)-Factor		0,15	0,17	0,17	0,18

**Displacement-Factors for shear load<sup>2)</sup>**

$\delta_{V,C2}$ (DLS)-Factor	[mm/kN]	0,18	0,10	0,07	0,06
$\delta_{V,C2}$ (ULS)-Factor		0,25	0,14	0,11	0,09

1) Calculation of effective displacement:

$$\delta_{N,C2} (DLS) = \delta_{N,C2} (DLS)\text{-Factor} \cdot \tau_{Ed}$$

$$\delta_{N,C2} (ULS) = \delta_{N,C2} (ULS)\text{-Factor} \cdot \tau_{Ed}$$

( $\tau_{Ed}$ : Design value of the applied tensile stress)

2) Calculation of effective displacement:

$$\delta_{V,C2} (DLS) = \delta_{V,C2} (DLS)\text{-Factor} \cdot V_{Ed}$$

$$\delta_{V,C2} (ULS) = \delta_{V,C2} (ULS)\text{-Factor} \cdot V_{Ed}$$

( $V_{Ed}$ : Design value of the applied shear force)

fischer Superbond

**Performances**

Characteristic values for combined pull-out and concrete failure under seismic action (performance category C2) for fischer anchor rods and standard threaded rods

**Annex C 16**

Appendix 40/ 40